

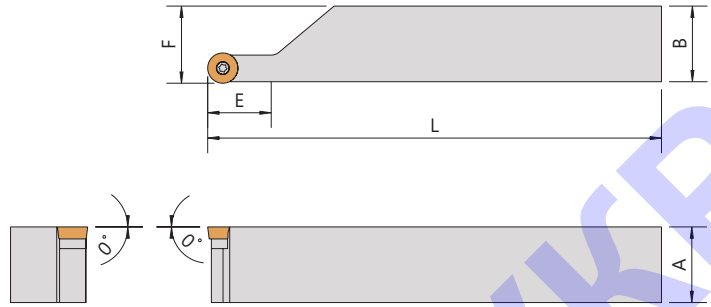

External Turning Tools 外徑車刀

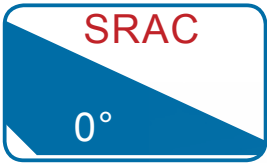

Order No.	Insert	Dimensions					Parts	Wrench
		A	B	L	E	F		
Right / Left								
SRACR/L-1010H05	RCMT0502	10	10	100	10	10.3	CS22050	FT-7
SRACR/L-1212H05		12	12	100	10	12.3	CS22050	FT-7
SRACR/L-1616H05		16	16	100	10	16.3	CS22050	FT-7
SRACR/L-2020K05		20	20	125	10	20.3	CS22050	FT-7
SRACR/L-2525M05		25	25	150	10	25.3	CS22050	FT-7
SRACR/L-1212H06	RCMT0602	12	12	100	12	12.4	CS25060	FT-7
SRACR/L-1616H06		16	16	100	12	16.4	CS25060	FT-7
SRACR/L-2020K06		20	20	125	12	20.4	CS25060	FT-7
SRACR/L-2525M06		25	25	150	12	25.4	CS25060	FT-7
SRACR/L-1616H08	RCMT0803	16	16	100	16	16.4	CS30070	FT-10
SRACR/L-2020K08		20	20	125	16	20.4	CS30070	FT-10
SRACR/L-2525M08		25	25	150	16	25.4	CS30070	FT-10
SRACR/L-2020K1003	RCMT1003 (MITSUBISHI)	20	20	125	20	20.4	CS30070	FT-10
SRACR/L-2525M1003		25	25	150	20	25.4	CS30070	FT-10

Order No.	Insert	Dimensions					Parts	Wrench			
		A	B	L	E	F					
Right / Left											
SRACR/L-2020K10	RCMT10T3	20	20	125	20	20.4	SMR-1003	SN535	CS35115	FT-15	LW035
SRACR/L-2525M10		25	25	150	20	25.4	SMR-1003	SN535	CS35115	FT-15	LW035