

Order No.	Insert	Dimensions				Parts	Wrench					
		A	B	L	F		Right / Left	Insert	Holder	Tool	Wrench	
WTJNR/L-2020K16	TNMG1604	20	20	125	25	SMT-322	LCS-420N	MWW-30	CSE5026	ER-4	LW025	LW030
WTJNR/L-2525M16	TNMG1604	25	25	150	32	SMT-322	LCS-420N	MWW-30	CSE5026	ER-4	LW025	LW030
WTJNR/L-3225P16	TNMG1604	32	25	170	32	SMT-322	LCS-420N	MWW-30	CSE5026	ER-4	LW025	LW030
WTJNR/L-3232P16	TNMG1604	32	32	170	40	SMT-322	LCS-420N	MWW-30	CSE5026	ER-4	LW025	LW030

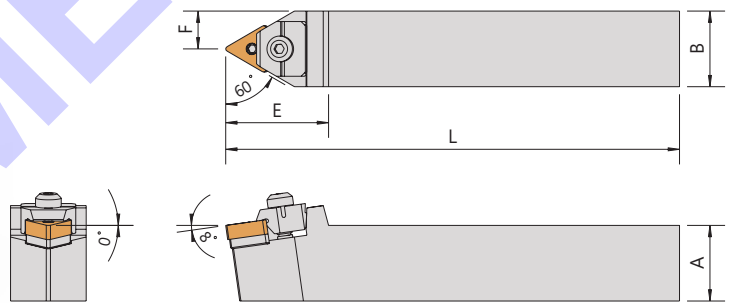
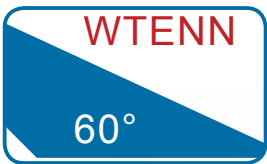

Order No.	Insert	Dimensions				Parts	Wrench					
		A	B	L	F		Right / Left	Insert	Holder	Tool	Wrench	
WTENN-2020K16	TNMG1604	20	20	125	10	SMT-322	LCS-420N	MWW-30	CSE5026	ER-4	LW025	LW030
WTENN-2525M16	TNMG1604	25	25	150	12.5	SMT-322	LCS-420N	MWW-30	CSE5026	ER-4	LW025	LW030
WTENN-3225P16	TNMG1604	32	25	170	12.5	SMT-322	LCS-420N	MWW-30	CSE5026	ER-4	LW025	LW030
WTENN-3232P16	TNMG1604	32	32	170	16	SMT-322	LCS-420N	MWW-30	CSE5026	ER-4	LW025	LW030