

Order No.	Insert	Dimensions					Parts					Wrench
		Right / Left	A	B	L	E	F	Insert	Holder	Clamp	Locking Bolt	
PWLNR/L-1616H06	WNMG0604		16	16	100	25	20	SMW-322	CS-LSP3	CP-LL3	CS-LS3	LW025
PWLNR/L-2020K06	WNMG0604		20	20	125	25	25	SMW-322	CS-LSP3	CP-LL3	CS-LS3	LW025
PWLNR/L-2525M06	WNMG0604		25	25	150	25	32	SMW-322	CS-LSP3	CP-LL3	CS-LS3	LW025
PWLNR/L-2020K08	WNMG0804		20	20	125	25	25	SMW-423	CS-LSP4	CP-LL4	CS-LS4	LW030
PWLNR/L-2525M08	WNMG0804		25	25	150	25	32	SMW-423	CS-LSP4	CP-LL4	CS-LS4	LW030
PWLNR/L-3225P08	WNMG0804		32	25	170	25	32	SMW-423	CS-LSP4	CP-LL4	CS-LS4	LW030
PWLNR/L-3232P08	WNMG0804		32	32	170	30	40	SMW-423	CS-LSP4	CP-LL4	CS-LS4	LW030

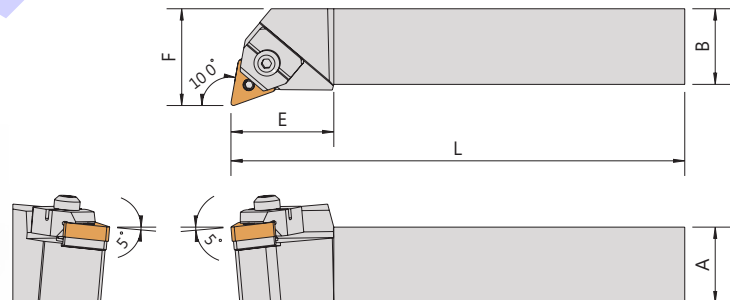
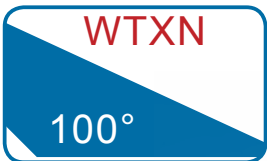

Order No.	Insert	Dimensions				Parts					Wrench		
		Right / Left	A	B	L	F	Insert	Holder	Clamp	Locking Bolt	Wrench 1	Wrench 2	
WTXNR/L-2020K16	TNMG1604		20	20	125	25	SMT-322	LCS-420N	MWW-30	CSH04124	ER-4	LW025	LW030
WTXNR/L-2525M16	TNMG1604		25	25	150	32	SMT-322	LCS-420N	MWW-30	CSH04124	ER-4	LW025	LW030