

Order No.	Insert	Dimensions					Parts				Wrench	
		Right / Left	A	B	L	E	F	Insert	Holder	Locking Bolt	Wrench	
MVJNR/L-2020K16	VNMG1604	20	20	125	39	25	SMV-322	LCS-513	CP50-25	CS7-6030	LW020	LW030
MVJNR/L-2525M16	VNMG1604	25	25	150	44	32	SMV-322	LCS-513	CP50-25	CS7-6030	LW020	LW030
MVJNR/L-3225P16	VNMG1604	32	25	170	44	32	SMV-322	LCS-513	CP50-25	CS7-6030	LW020	LW030
MVJNR/L-3232P16	VNMG1604	32	32	170	45	40	SMV-322	LCS-513	CP50-25	CS7-6030	LW020	LW030

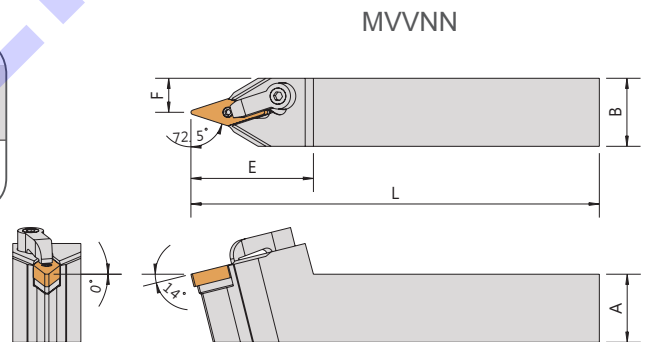
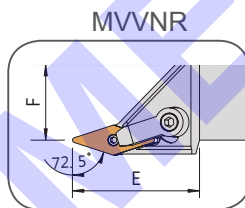
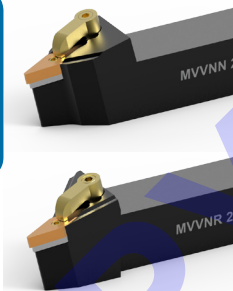
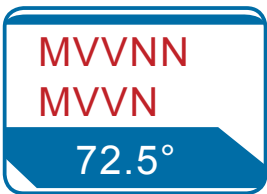

Order No.	Insert	Dimensions					Parts				Wrench	
		Right / Left	A	B	L	E	F	Insert	Holder	Locking Bolt	Wrench	
MVVNN-2020K16	VNMG1604	20	20	125	45	10	SMV-322	LCS-513	CP50-25	CS7-6030	LW020	LW030
MVVNN-2525M16	VNMG1604	25	25	150	45	12.5	SMV-322	LCS-513	CP50-25	CS7-6030	LW020	LW030
MVVNN-3225P16	VNMG1604	32	25	170	45	12.5	SMV-322	LCS-513	CP50-25	CS7-6030	LW020	LW030
MVVNN-3232P16	VNMG1604	32	32	170	45	16	SMV-322	LCS-513	CP50-25	CS7-6030	LW020	LW030
MVVNR/L-2020K16	VNMG1604	20	20	125	42	20	SMV-322	LCS-513	CP50-25	CS7-6030	LW020	LW030
MVVNR/L-2525M16	VNMG1604	25	25	150	42	25	SMV-322	LCS-513	CP50-25	CS7-6030	LW020	LW030