

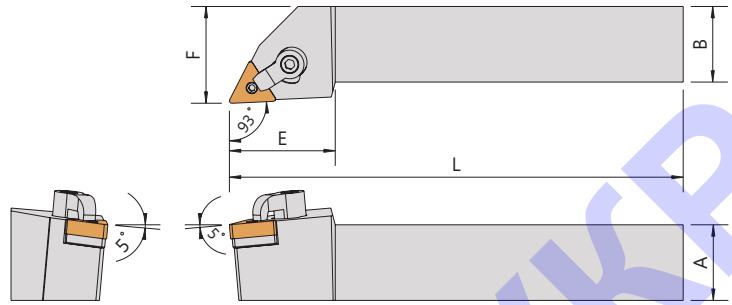

External Turning Tools 外徑車刀

MTJN
MTJN-N
93°



Order No.	Insert	Dimensions						Parts			Wrench		
		Right / Left		A	B	L	E	F					
MTJNR/L-1616H16	TNMG1604		16	16	100	30	20	SMT-322	LCS-513	CP50-22	CS7-6024	LW020	LW030
MTJNR/L-2020K16	TNMG1604		20	20	125	33	25	SMT-322	LCS-513	CP50-22	CS7-6024	LW020	LW030
MTJNR/L-2525M16	TNMG1604		25	25	150	35	32	SMT-322	LCS-513	CP50-22	CS7-6030	LW020	LW030
MTJNR/L-3225P16	TNMG1604		32	25	170	43	32	SMT-322	LCS-513	CP50-22	CS7-6030	LW020	LW030
MTJNR/L-3232P16	TNMG1604		32	32	170	43	40	SMT-322	LCS-513	CP50-22	CS7-6030	LW020	LW030
MTJNR/L-2525M22	TNMG2204		25	25	150	43	32	SMT-433	LCS-617	CP50-28	CS7-8030	LW030	LW040
MTJNR/L-3225P22	TNMG2204		32	25	170	43	32	SMT-433	LCS-617	CP50-28	CS7-8030	LW030	LW040
MTJNR/L-3232P22	TNMG2204		32	32	170	43	40	SMT-433	LCS-617	CP50-28	CS7-8030	LW030	LW040
MTJNR/L-4040S22	TNMG2204		40	40	250	43	50	SMT-433	LCS-617	CP50-28	CS7-8030	LW030	LW040
MTJNR/L-4040S27	TNMG2706		40	40	250	43	50	SMT-534	LCS-0822	CP50-28	CS7-8030	LW030	LW040
MTJNR/L-1212H16N	TNMG1604		12	12	100	30	12	—	LCS-510	CP50-22	CS7-6024	LW020	LW030
MTJNR/L-1616H16N	TNMG1604		16	16	100	30	16	SMT-322	LCS-513	CP50-22	CS7-6024	LW020	LW030

MTAN
90°

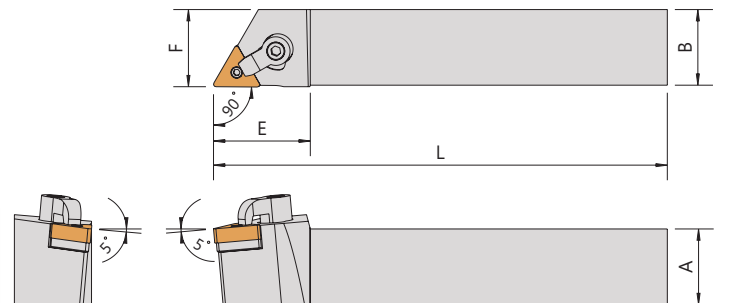

Order No.	Insert	Dimensions						Parts			Wrench		
		Right / Left		A	B	L	E	F					
MTANR/L-2020K16	TNMG1604		20	20	125	32	20.5	SMT-322	LCS-513	CP50-22	CS7-6030	LW020	LW030
MTANR/L-2525M16	TNMG1604		25	25	150	32	25.5	SMT-322	LCS-513	CP50-22	CS7-6030	LW020	LW030