

Machine dimensions

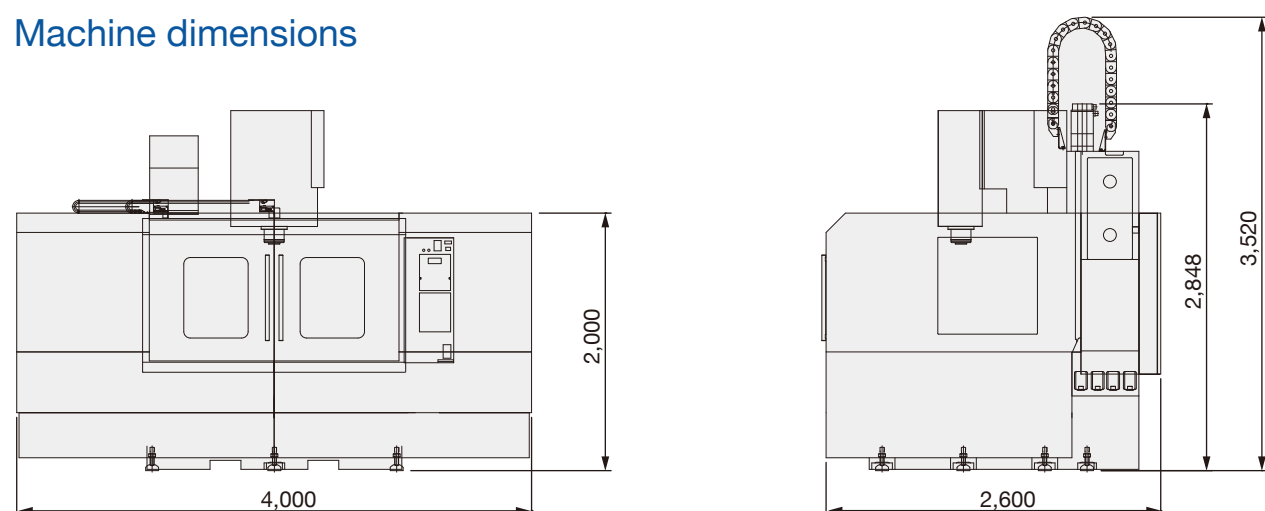

Unit : mm

Specification

Item	Specification	Unit	TMV-1500A (#40)	TMV-1500A (#50)
Table	Table size (L×W)	mm	1,600x762	
	Max.table load	kg	1,869	
	Table height from floor	mm	950	
	T-slot (size×No.)	mm	18x7	
Spindle	Spindle taper		7/24 Taper No.40	7/24 Taper No.50
	Spindle speed		8,000 (10,000)	Belt-driven type 6,000 (opt. 3,500)
Stroke	X/Y/Z axis stroke	mm	1,525/762/710	
	Spindle nose to table	mm	100-810	
Feed	X/Y/Z axis rapid traverse	m/min	18/18/18	
	Cutting feedrate	mm/min	1-10,000	
ATC	Tool shank		BT-40 (CAT-40)	BT-50 (CAT-50)
	Tool capacity	pc	24	
	Max. tool diameter	mm	Ø89	Ø110
	Max. tool diameter (w/o adjacent tool)	mm	Ø125	Ø200
	Max. tool length	mm	250	300
	Max. tool weight	kg	7	15
Motor	Spindle motor	kW	15/11	11/15
	X/Y/Z servo motor	kW	3.0/4.0/7.0	
	Coolant motor	kW	0.37	
Machine size	W×L×H	mm	4,000×3,600×3,520	
	Weight	kg	13,000	13,500
Controller			FANUC Oi-MF	

©Specifications may be changed without prior notice

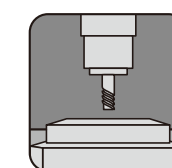

Vertical Machining Center

TMV-1500A



Tongtai Tongtai Machine & Tool Co., Ltd.

Headquarters

No.3, Luke 3rd Rd., Luzhu Dist., Kaohsiung City 82151, Taiwan
TEL : 886-7-9761588 FAX : 886-7-9761589
www.tongtai.com.tw

Taoyuan Branch TEL : 886-3-4551399 FAX : 886-3-4559730
Taichung Branch TEL : 886-4-23589600 FAX : 886-4-23589993
Japan Branch TEL : 81-4-71438355 FAX : 81-4-71438360
Europe Branch TEL : 31-161-454639 FAX : 31-161-454768
Romania Branch TEL : 40-264-415273 FAX : 40-264-403983
Malaysia Branch TEL : 603-78597113 FAX : 603-78597115
Vietnam Branch TEL : 84-4-62766090
Thailand Branch TEL : 66-2-7443440 FAX : 66-2-3986518
Indonesia Office TEL : 62-21-45850875 FAX : 62-21-45850876

Affiliates

Honor Seiki Co., Ltd.
TEL : 886-7-9759888
FAX : 886-7-9759999
www.honorseiki.com.tw

Asia Pacific Elite Corp.
TEL : 886-4-23589313
FAX : 886-4-23588913
www.apecnc.com

Quick-Tech Machinery Co., Ltd
TEL : 886-6-3841155
FAX : 886-6-3841177
www.quicktech.com.tw

PCI-SCEMM
TEL : 33-4-77426161
FAX : 33-4-77426023
www.pci.fr

ANGER Machining GmbH
TEL : 43-7229-71041-0
FAX : 43-7229-71041-199
www.anger-machining.com



MEMBER OF

TGROUP

China Operation Center

Shuzhou Tong-yu Machine & Tool Co., Ltd.

No.555 Huahong Rd., Economic Development Zone of Wujiang,
Suzhou City, Jiangsu Province, China
TEL : 86-512-63430168
FAX : 86-512-63431622
E-mail : sales@tong-yu.com.cn

Wuhan Branch TEL : 86-27-84586587 FAX : 86-27-84853595
Chongqing Branch TEL : 86-23-67865925 FAX : 86-23-67867717
Guandong Branch TEL : 86-769-81158198 FAX : 86-769-81158108
Tianjin Branch TEL : 86-22-24417640 FAX : 86-22-24416738
Shanghai Office TEL : 86-21-24208138 FAX : 86-21-34073262
Shenyang Office TEL : 86-24-24142968 FAX : 86-24-24115782

TMV-1500 2017.08.03 ©All the specifications in the brochure are subject to change without prior notice.

MEMBER OF

TGROUP

www.tongtai.com.tw

TMV-1500A

Spindle

Available in both 40 and 50 tapers, the grease lubricated cartridge spindles are liquid cooled. The spindle cooler reduces thermal deformation and extends spindle life. Standard 8,000 rpm belt-driven 40 taper spindle can optionally be changed to 10,000 rpm for high speed machining. Furthermore, BT-50 6,000 rpm, 3,500 rpm belt-driven spindle are also available for heavy cutting.

	40 taper		50 taper	
	Max. speed	10,000 rpm	6,000 rpm	3,500 rpm
Horse power	9/7.5 kW	18/15/11 kW	15/11 kW	15/11 kW
Torque	114/95 Nm	44/36/26 Nm	191/140 Nm	239/175 Nm



Belt-driven 8,000 rpm (40 taper) (Standard)

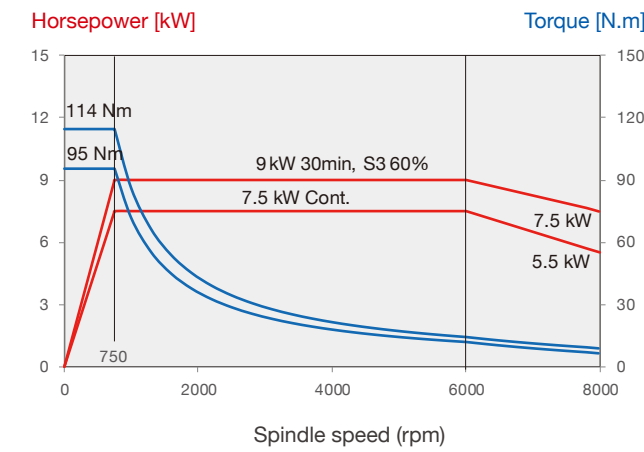

Belt-driven 10,000 rpm (40 taper) (Optional)

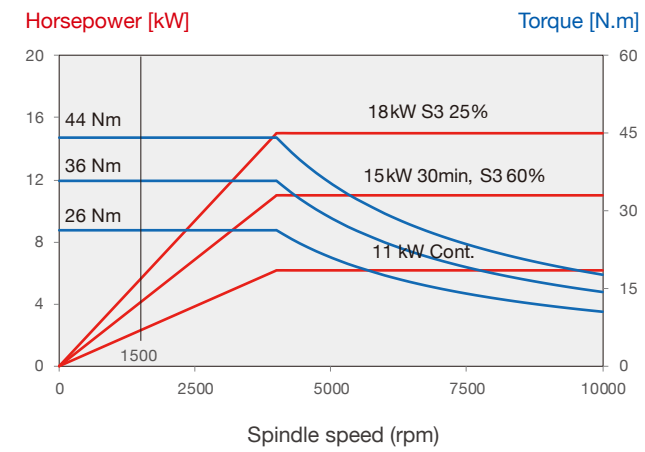

Belt-driven 6,000 rpm (50 taper) (Optional)

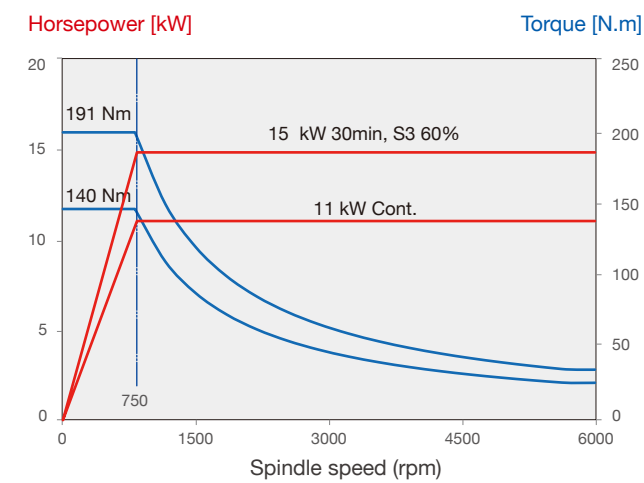

Belt-driven 3,500 rpm (50 taper) (Optional)

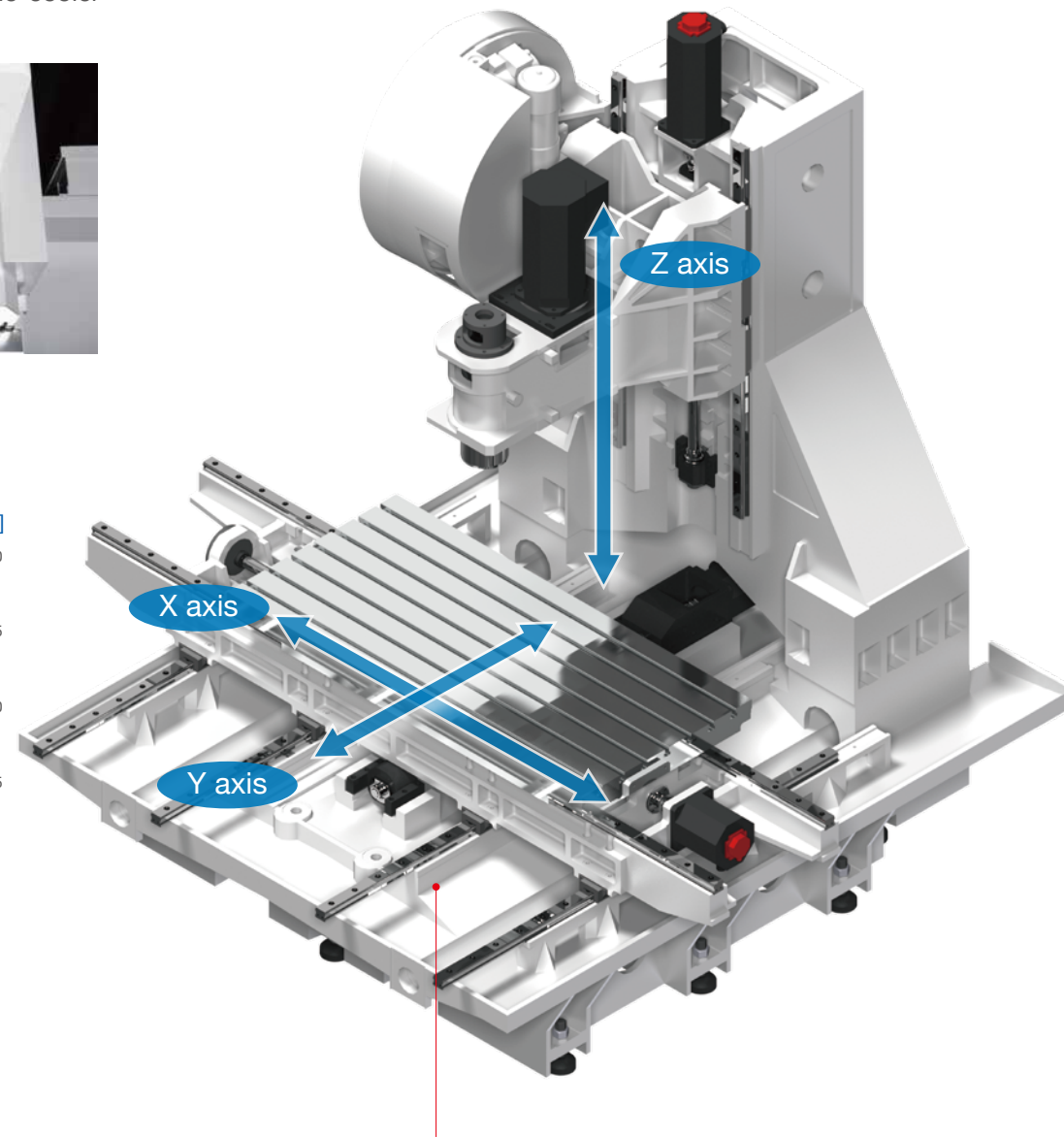
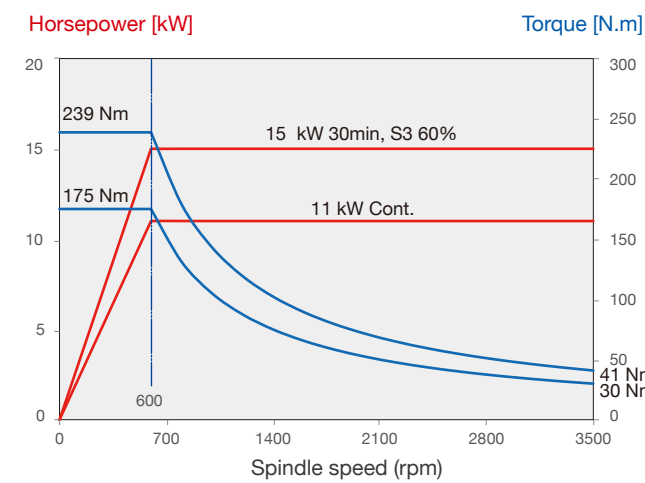

Casting components on this machine are made of high quality cast iron, and through finite element analysis (FEA), the static and dynamic rigidity can be ensured.

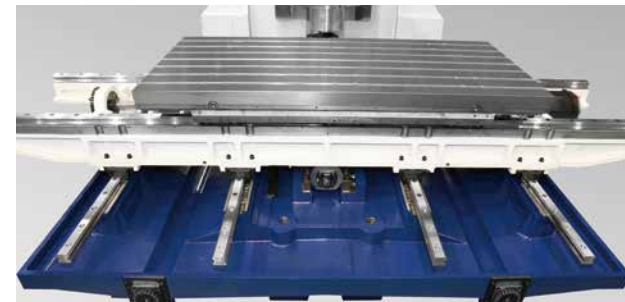

The Y axis employs four guideways to offer superior support of the X axis saddle and best accuracy.

Stroke

X/Y/Z axis 1,525/762/710 m/min

Rapid traverse

X/Y/Z axis 18/18/18 m/min

ATC

The cam-type tool changer has higher accuracy and lower noise. In addition, the stable tool clamping can ensure spindle accuracy and expand bearing life.

	40 taper	50 taper
T to T	3.0 sec	5.1 sec
Tool capacity	24 tools 30 tools (Optional)	24 tools 32 tools (Optional)

Working area

Table size 1,600 mm x 762 mm
Max. load 1,869 kg

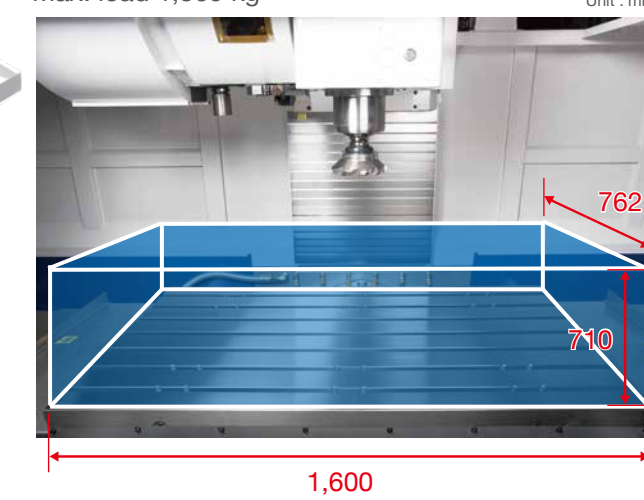

Chip disposal

Equipped with two chip augers and flushing system, even heavy chip loads are evacuated efficiently.



Operation

With the door opened, the top side is wide open, providing a wide space for loading work.

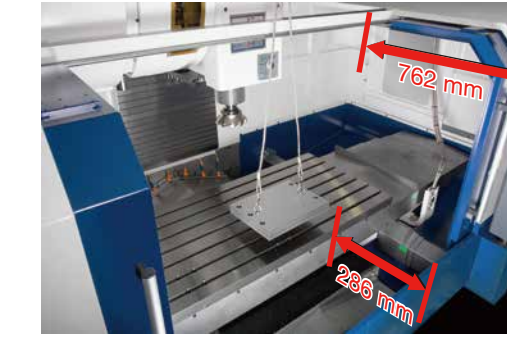

The distance and height of table are very ergonomic. It provides the operator a very comfortable and convenient working area.



Maintenance

The wide door opening provides a spacious area for the operator during operation and processing maintenance.

Door opening width 1,664 mm

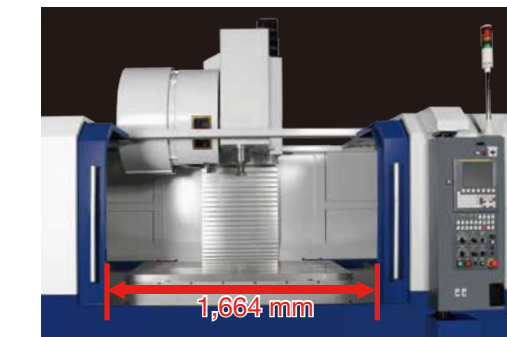

Pneumatic units, lubricant pump, and some maintenance items are located on the rear side of machine, with easy access.



Standard/Optional accessories

	Standard	Optional
Tool Shank	BT-40	BT-50
Coolant through spindle pump	15 bar	40 bar
	70 bar	
Cooling system	Spindle coolant system	
	Hydraulic temperature control system	
	Coolant temperature control system	
	Air conditioner for electrical cabinet	
Chip conveyor	Two chip augers	
	Bed flushing pump	
	Scraper type conveyor	
	Magnetic scraper type conveyor	
	Hinge type conveyor	

	Standard	Optional
Lubrication system	General lubrication system	
	LHL integrated lubrication system	
Positioning accuracy system	Three axes linear scale 5μ resolution	
	Three axes linear scale 3μ resolution	
	Three axes magnetic scale 5μ resolution	
Tool measuring system	Tongtai made touch type tool breakage detector	
	Laser type tool measurement	
4th axis rotatory table		
Others	Workpiece measuring device	
	Machining air blow	
	Air gun	
	Coolant gun	
	Oil skimmer	
	Oil mist collector	
Controller	FANUC Oi-M	
	FANUC 31i-M	