

Multi-tasking Turning Center

TD Series



Tongtai Tongtai Machine & Tool Co., Ltd.

Headquarters

No.3, Luke 3rd Rd., Luzhu Dist., Kaohsiung City 82151, Taiwan

TEL : 886-7-9761588 FAX : 886-7-9761589

www.tongtai.com.tw

Taoyuan Branch	TEL : +886-3-4551399	FAX : +886-3-4559730
Taichung Branch	TEL : +886-4-23589600	FAX : +886-4-23589993
Japan Branch	TEL : +81-047-712-0835	FAX : +81-047-712-0870
Europe Branch	TEL : +31-161-454639	
Malaysia Branch	TEL : +603-78597113	FAX : +603-78597115
Vietnam Branch	TEL : +84-24-62766090	
Thailand Branch	TEL : +66-2-3164708-10	FAX : +66-2-3164711
Indonesia Office	TEL : +62-21-45850875	FAX : +62-21-45850876

Members of TTGroup

Honor Seiki Co., Ltd.
TEL : 886-7-9759888
FAX : 886-7-9759999
www.honorseiki.com

Asia Pacific Elite Corp.
TEL : 886-4-23589313
FAX : 886-4-23588913
www.apecnc.com

Quick-Tech Machinery Co., Ltd.
TEL : 886-6-3841155
FAX : 886-6-3841177
www.quicktech.com.tw

PCI-SCEMM
TEL : 33-4-77426161
FAX : 33-4-77426023
www.pci.fr

ANGER Machining GmbH
TEL : 43-7229-71041-0
FAX : 43-7229-71041-199
www.anger-machining.com

MEMBER OF
TTGROUP



Official Website Global Network

China Operation Center

Shuzhou Tong-yu Machine & Tool Co., Ltd.

No.555 Huahong Rd., Economic Development Zone of Wujiang,
Suzhou City, Jiangsu Province, China

TEL : 86-512-63430168 FAX : 86-512-63431622

E-mail : sales@tong-yu.com.cn

www.tongtai.com.tw/cn

Wuhan Branch	TEL : +86-27-84586587
Chongqing Branch	TEL : +86-23-67865925 FAX : +86-23-67867717
Guandong Branch	TEL : +86-769-81158198 FAX : +86-769-81158108
Tianjin Branch	TEL : +86-22-24417640 FAX : +86-22-24416738
Shanghai Office	TEL : +86-21-24208138 FAX : +86-21-34073262
Shenyang Office	TEL : +86-24-24142968 FAX : +86-24-24115782

TD Series . 2018.10.02 ©All the specifications in the brochure are subject to change without prior notice.

MEMBER OF
TTGROUP

www.tongtai.com.tw

TD series

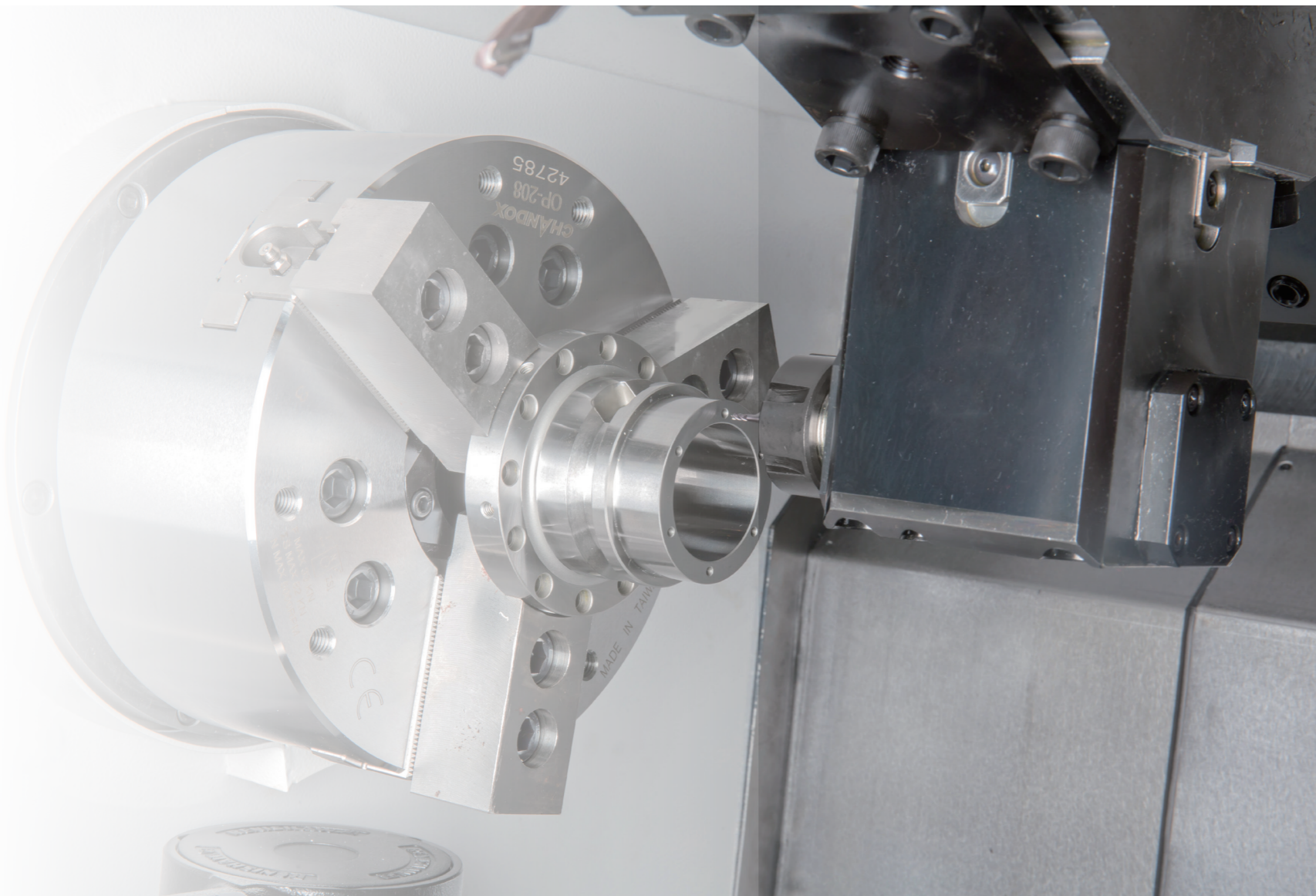

■ Rigidity is better than the past

Inheriting the outstanding machine rigidity from TB series, the TD series is the brand new multi-tasking turning center with single power turret which standard equipped with 12 tool stations and linear Y axis to process milling function. In addition, for customer's needs, the 16 tool stations turret and sub-spindle is also available for more complex machining process, it helps to reduce labor costs and increase floor utility.

■ 75 degree machine bed structure

Different from the 90 degree slant bed on TB series, the TD series adopts a 75 degree slant bed design. It not only keeps the advantages of excellent chip disposal and accessibility, but also lowers the machine's gravity center for enhancing the entire structure rigidity.

■ Linear Y axis structure

TD series adopts a symmetrically saddle design, the X/Y/Z axis are perpendicular to each other with a real linear Y axis. It allows servo compensation on each axis to optimize the positioning accuracy.



CONTENTS

- 03 Machining ability
- 04 Main Structure
- 07 Operation
- 08 Peripheral accessories
- 09 For green future
- 10 Spindle output and torque chart
- 11 Tool system
- 13 Tool interference
- 15 Working area
- 21 Standard/optional accessories
- 22 Machine dimension • Specifications

	Spindle diameter	Bar capacity	Tailstock/Sub-Spindle	Model
Chuck size 8"	Ø100 mm	Ø51 mm	Tailstock	TD-2000Y
		Ø51 mm	Sub-Spindle(without CS axis)	TD-2000YB
		Built in type	Sub-Spindle(with CS axis)	TD-2000YBC
Chuck size 10"	Ø120 mm	Ø64 mm	Tailstock	TD-2500Y
		Ø51 mm	Sub-Spindle(without CS axis)	TD-2500YB
		Built in type	Sub-Spindle(with CS axis)	TD-2500YBC
	Ø130 mm	Ø74 mm	Tailstock	TD-2500Y
		Ø64 mm	Sub-Spindle(without CS axis)	TD-2500YB
		Built in type	Sub-Spindle(with CS axis)	TD-2500YBC

Machining ability

Turning Material:S45C

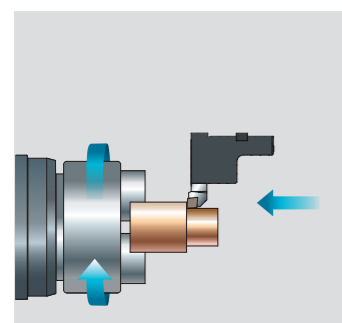
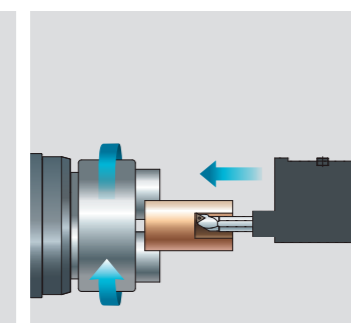
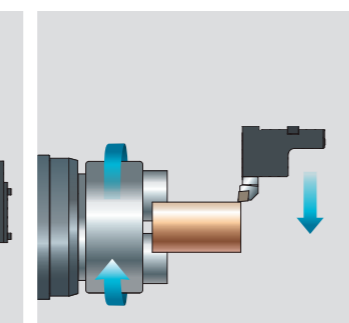
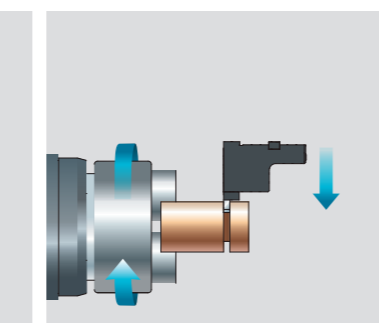
			
O.D. turning	I.D. turning	Face turning	Grooving
Material removal rate	360 cm ³ /min	Material removal rate	360 cm ³ /min
Cutting depth	6 mm	Cutting depth	6 mm
Spindle speed	764 rpm	Spindle speed	764 rpm
Feedrate	0.5 mm/rev	Feedrate	0.5 mm/rev
Cutting speed	120 m/min	Cutting speed	120 m/min
Material removal rate	6 mm	Material removal rate	6 mm
Feedrate	0.4 mm/rev	Feedrate	0.4 mm/rev
Cutting speed	120 m/min	Cutting speed	120 m/min

Milling Material:S45C

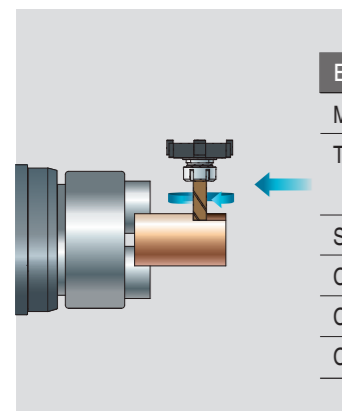
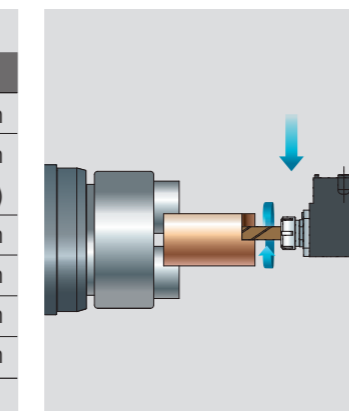
	
End milling	End milling
Material removal rate	45 cm ³ /min
Tool	end mill Ø20 mm (4 teeth)
Spindle speed	557 rpm
Cutting feedrate	220 mm/min
Cutting width	20 mm
Cutting depth	10 mm

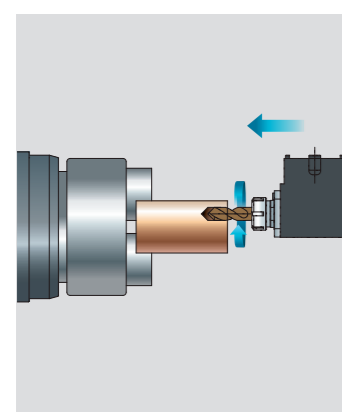
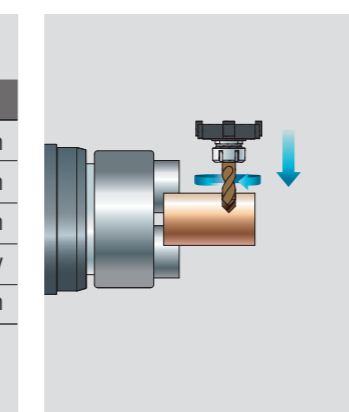
	
Drilling	Drilling
Material removal rate	71 cm ³ /min
Tool	drill Ø20 mm
Spindle speed	1512 rpm
Feedrate	0.15 mm/rev
Cutting speed	95 m/min

※Note: Above data are the test result of TD-2000YB

Main Structure

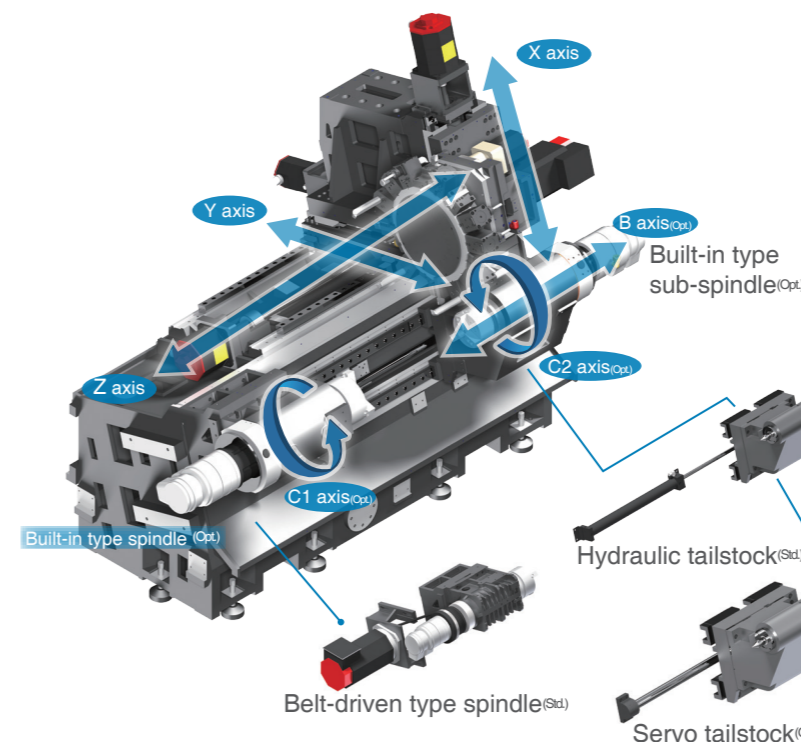

Working area

X/Y/Z axis	230/±51/600 mm
B axis(Opt.)	630 mm
Hydraulic tailstock	600 mm
Servo tailstock(Opt.)	600 mm

Rapid traverse

X/Y/Z axis	30/15/30 m/min
B axis(Opt.)	30 m/min
Servo tailstock(Opt.)	30 m/min

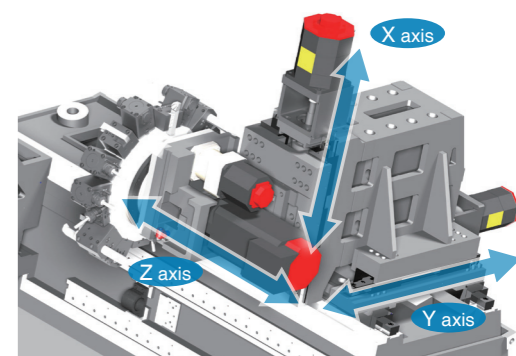

Real Y axis structure

Different from the virtual Y axis, the real Y axis has excellent straightness and positioning accuracy which is able to ensure high machining quality. With a highly rigid sliding carrier design, the TD series has outstanding machining capability.

Working area

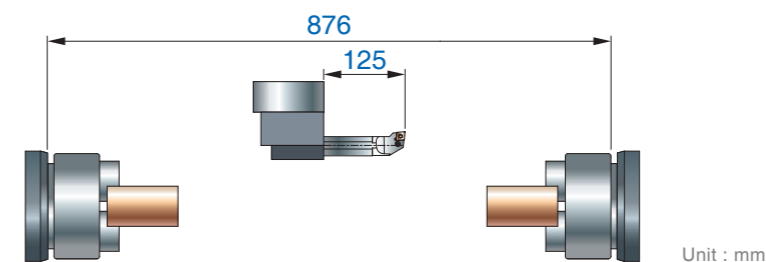

Sub-spindle type

	Belt-driven type spindle		Built-in type spindle	
	VDI tool system	BMT tool system	VDI tool system	BMT tool system
	12V VDI-40	16V VDI-30	12V BMT-65	16V BMT-55
Max. tool length of reverse tool	125	125	125	125
Max. machining dia.	390	410	360	370
Max. machining length	535 (560)	545 (570)	505 (530)	510 (535)

Tailstock type

	Belt-driven type spindle		Built-in type spindle	
	VDI Tooling system	BMT Tooling system	VDI Tooling system	BMT Tooling system
	12V VDI-40	16V VDI-30	12V BMT-65	16V BMT-55
Max. machining dia.	390	410	360	370
Max. machining length	560 (585)	570 (595)	530 (555)	535 (560)

Unit : mm

Main structure

Main spindle

Model	TD-2000Y	TD-2500Y	
Bar capacity	Ø51 mm (* Ø51 mm)	Ø64 mm (* Ø51 mm)	Ø74 mm (* Ø64 mm)
Spindle bearing diameter	Ø100 mm	Ø120 mm	Ø130 mm
Chuck size	8"	10"	
Max. spindle speed	4,500 rpm (* 6,000 rpm)	3,500 rpm (* 5,000 rpm)	3,500 rpm (* 3,500 rpm)
Spindle motor	18.5/15/11 kW (* 18.5/11kW)	18.5/15/11 kW (* 25/22kW)	18.5/15/11 kW (* 15/11kW)

(* = Built-in type motor)

Sub-spindle

Spindle bearing diameter	Ø90 mm
Chuck size	6"
Max. spindle speed	5,000 rpm
Spindle motor	7.5/5.5 kW
Driving method	Built-in type motor

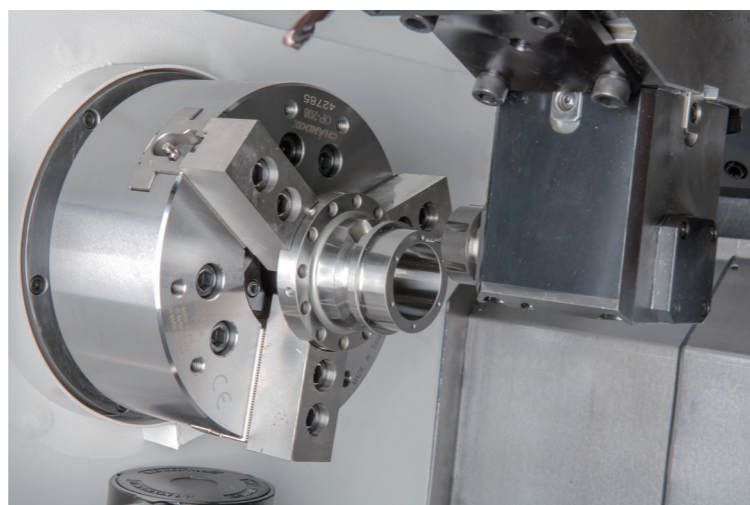

Spindle/Sub-spindle CS axis with brake unit

The CS axis is fed back by a rotary encoder with multi-points positioning function. The minimum indexing increment of 0.001 degrees allows various machining needs with different angles.

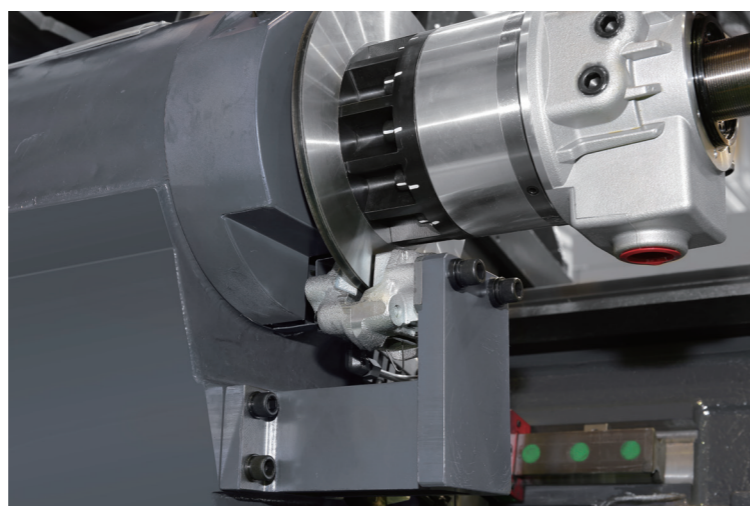
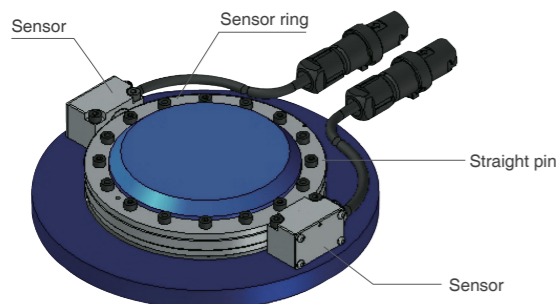

Sub-spindle cooler

With synchronous temperature control, the spindle cooler prevents sub-spindle from thermal distortion. This ensures high precision machining for long-term operation.

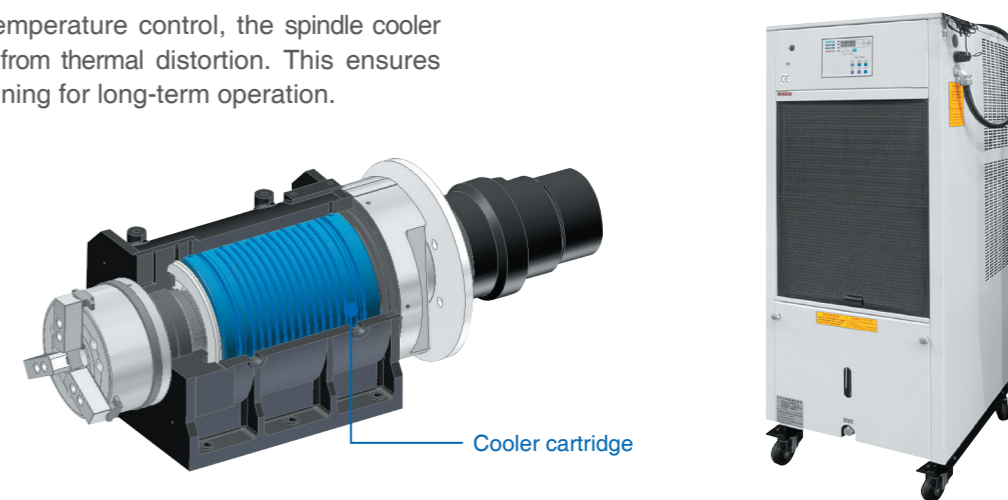

Turret

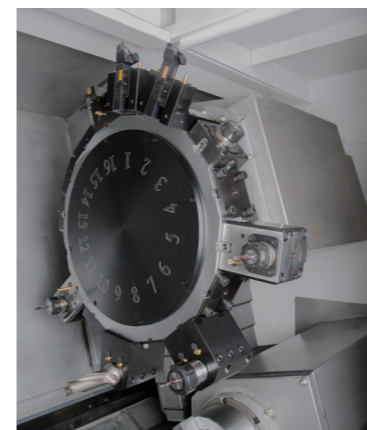

Tool shank	VDI-	BMT-65(Std.)	VDI-	BMT-55(Opt.)
Tool capacity	40(Opt.)	12	30(Opt.)	16
Indexing time (adjacent tool)	0.3 sec		16 0.25 sec	
Indexing time (opposite tool)	1 sec		1 sec	
Max. live tool speed	6,000 rpm			
spindle output of live tool	5.5/3.7 kW			

Robust structure

All components are made of high quality cast-iron. With excellent design, the structure is able to decrease the influences of distortion and vibration. In addition, with the Finite Element Analysis (FEA), the structure is improved and can satisfy the requirements of high dynamic rigidity and stability.

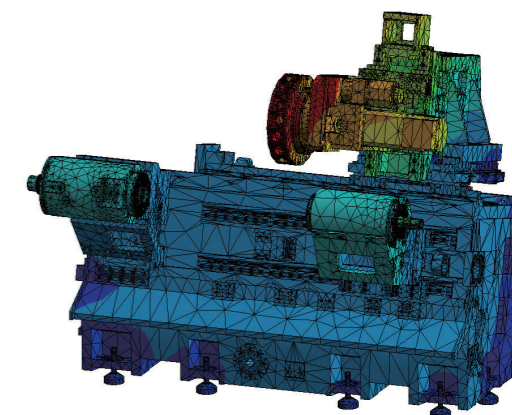

Operation

Swivel-type operation panel



The swivel panel makes operator easy to operate and inspect during operation.

Accessibility

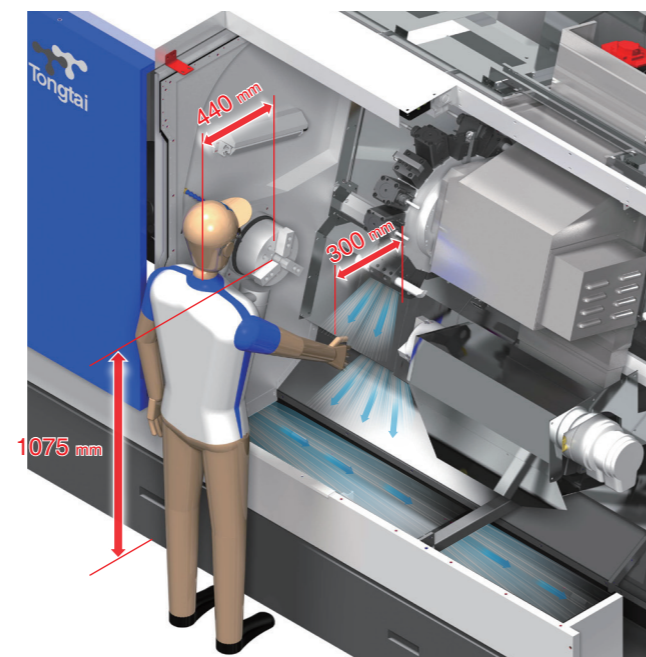

75 degree machine bed design facilitates the chips disposal and spindle accessibility.

Peripheral accessories

Chip conveyor

According to different workpiece materials and chips, the clients can to select suitable conveyors for achieving the best chip disposal. Tongtai provides various chip conveyors for our clients' convenience.

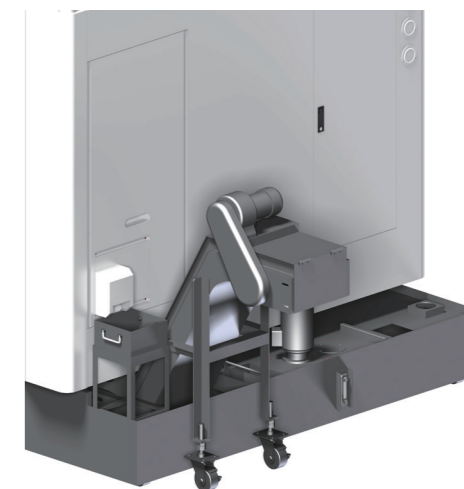

Coolant tank capacity
400 L (80% full)

Specification	Steel		Cast iron		Aluminum/ Non-ferrous metal		
	Long/Curl chips	Short chips	Powder chips	Short chips	Long/Curl chips	Short chips	Powder chips
Hinge type	○	×	×	×	○	×	×
Scraper type	×	○	○	○	×	○	○
Magnetic scraper type	×	○	○	○	○	×	×

○ : Suitable x : Non-suitable

Short chips : Chips shorter than Ø60 mm or ball type chips smaller than Ø40 mm.
Curl long chips : Chips' length is longer than short ones.

Front-pull coolant tank



Coolant tank is able to be pulled from the front of the machine. It saves floor space and facilitates the maintenance.

Easier daily maintenance



Through centralized management of pneumatic solenoid and lubrication pump, it made the daily maintenance easy.

parts catcher (optional)

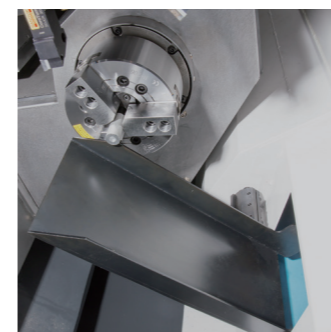

Manual tool presetter (optional)

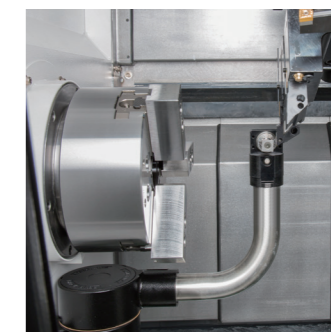

Disc type oil skimmer (optional)

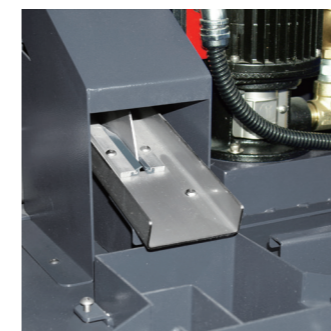

Oil mist collector (optional)



For green future

With rising energy costs and strict international environmental laws, equipment efficiency is a key factor that can influence the production costs. By this trend, the latest machine tools not only need to satisfy the requirements of high speed and high precision, but also need to pursue the goals of high efficiency and environmental protection. In recent years, Tongtai has worked hard on developing the products with the concept of environmentally friendly. Furthermore, energy saving accessory products are the primary concern to us.



LHL lubrication system

Variable-frequency hydraulic unit



Spindle output and torque chart

TD-2000Y Belt-driven type spindle motor

Spindle diameter Ø100 mm
Spindle speed 4500 rpm
Pulley ratio 1:1.25

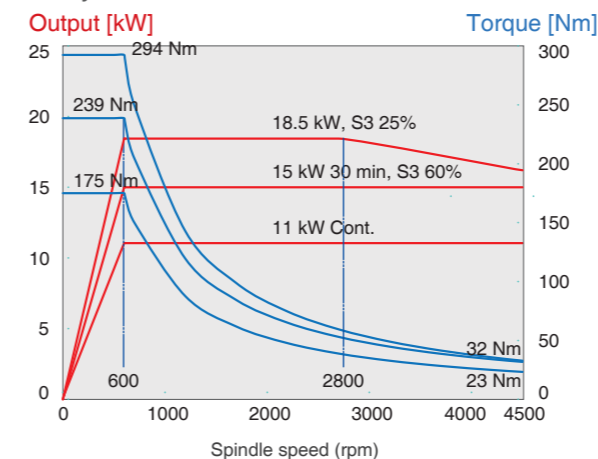

TD-2500Y Belt-driven type spindle motor

Spindle diameter Ø120 mm/Ø130 mm
Spindle speed 3500 rpm
Pulley ratio 1:1.25

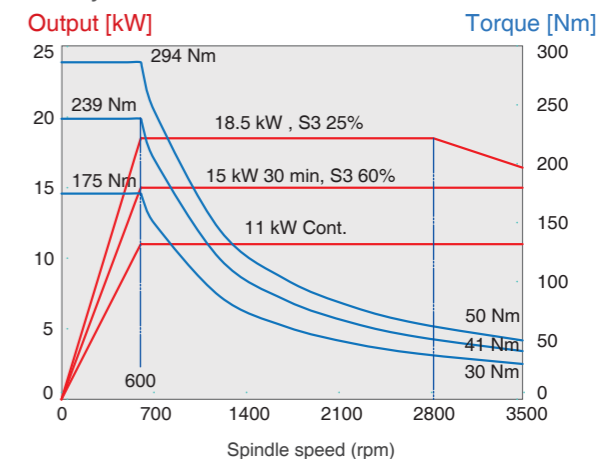

TD-2000Y Built-in type spindle motor (Opt.)

Spindle diameter Ø100 mm
Spindle speed 6000 rpm

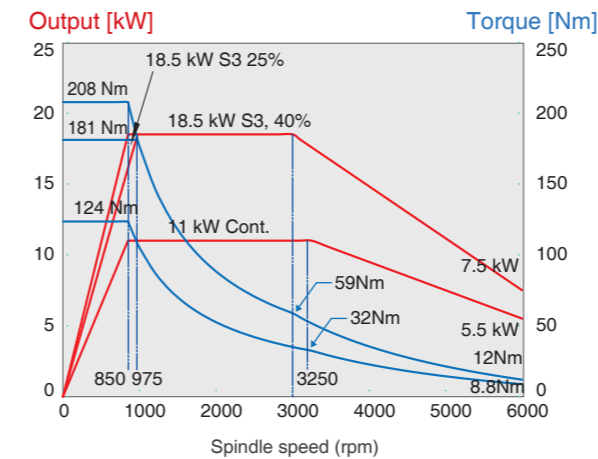

Built-in type sub-spindle motor

Spindle diameter Ø90 mm
Spindle speed 5000 rpm

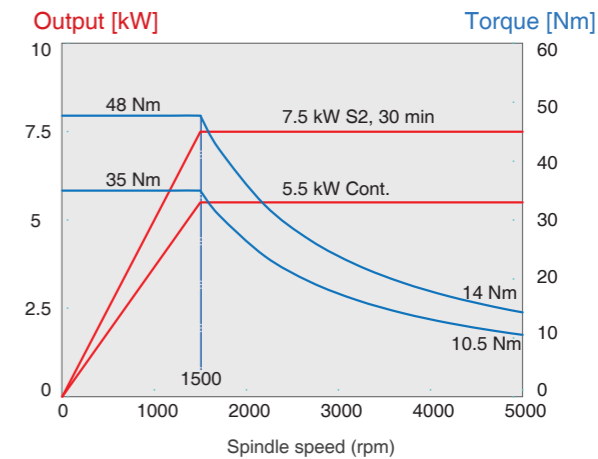

TD-2500Y Built-in type spindle motor (Opt.)

Spindle diameter Ø120 mm
Spindle speed 5000 rpm

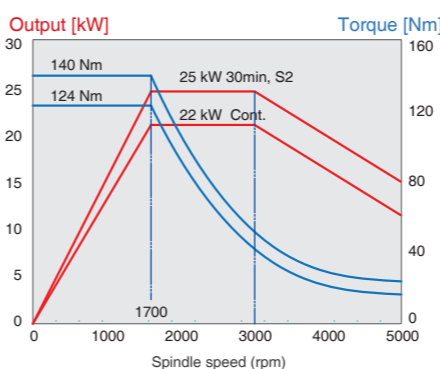

TD-2500Y Built-in type spindle motor (Opt.)

Spindle diameter Ø130 mm
Spindle speed 3500 rpm

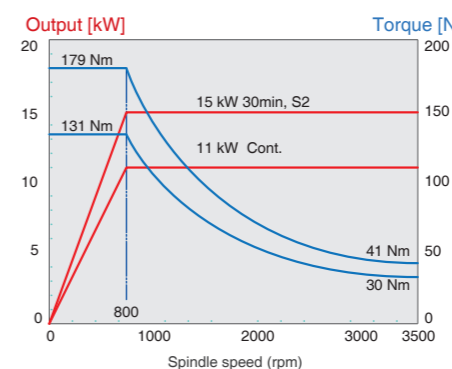

Live tool spindle motor

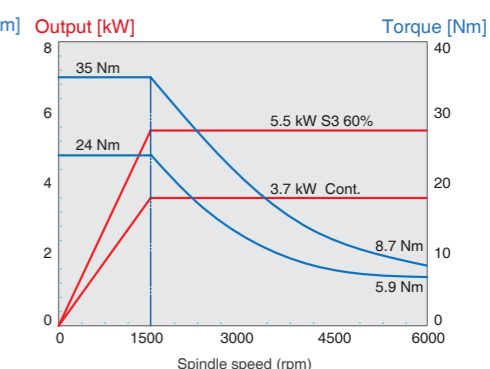

Tool system

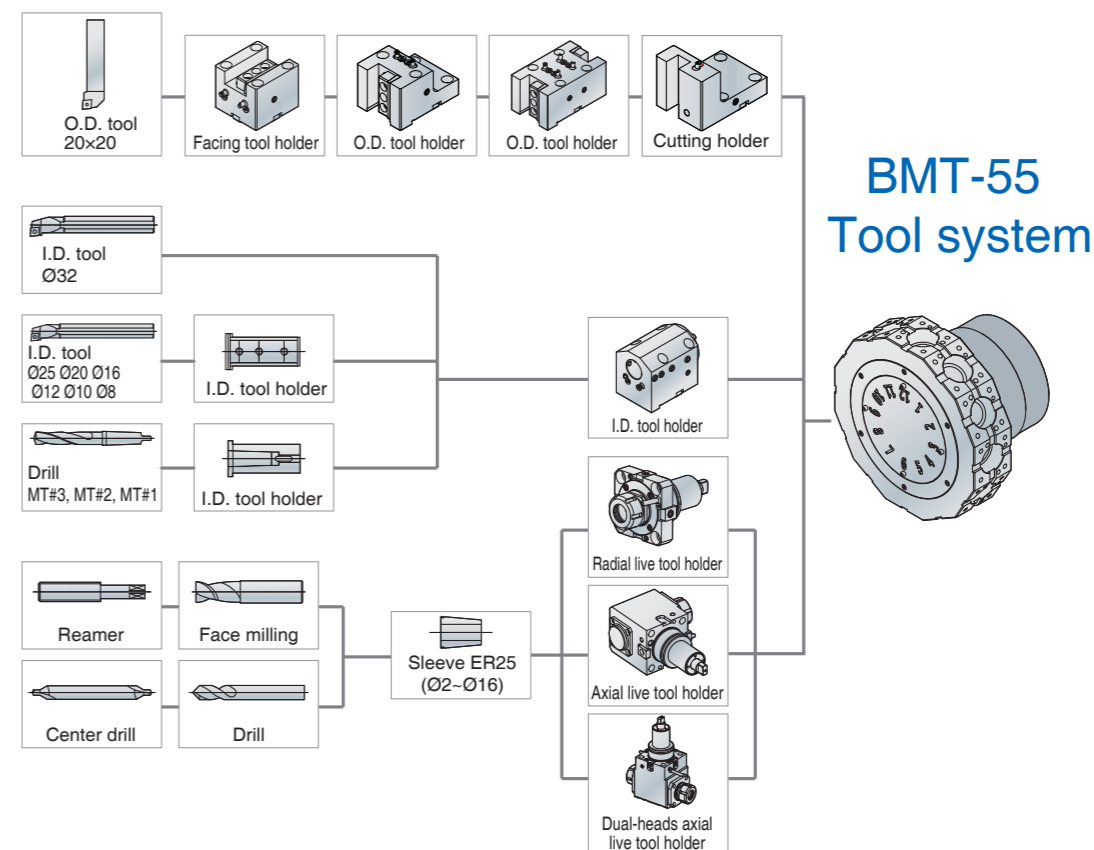
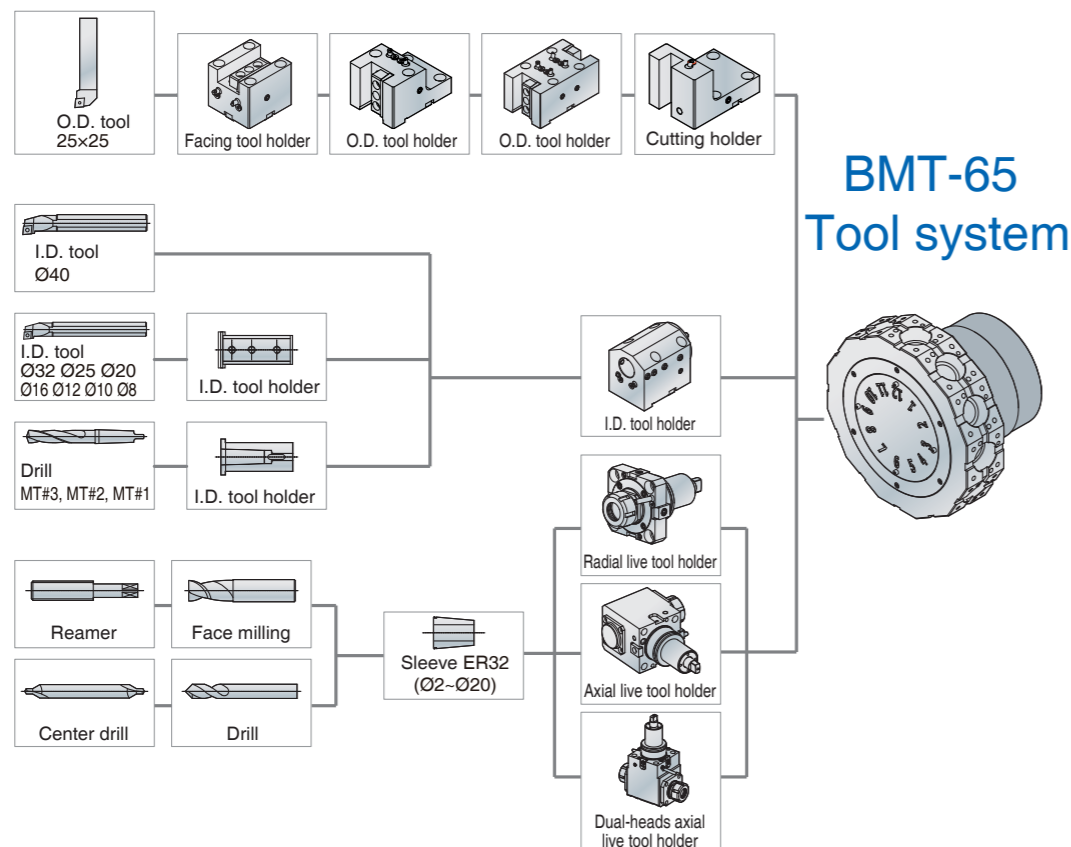
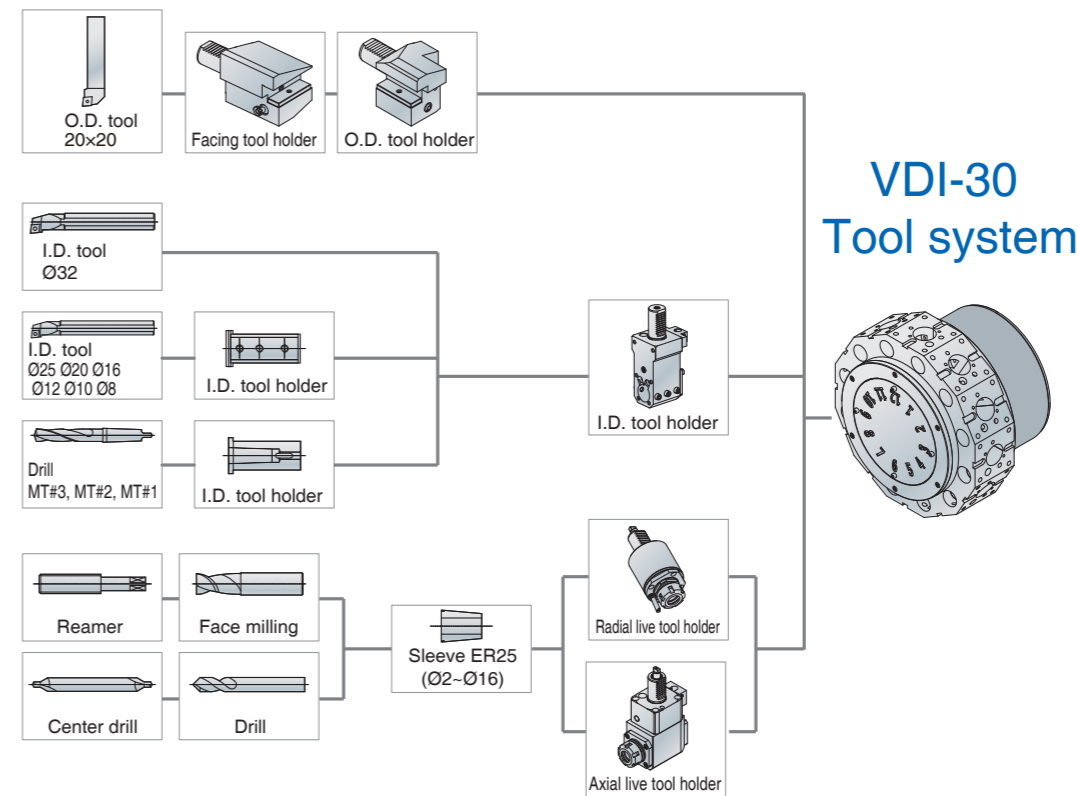
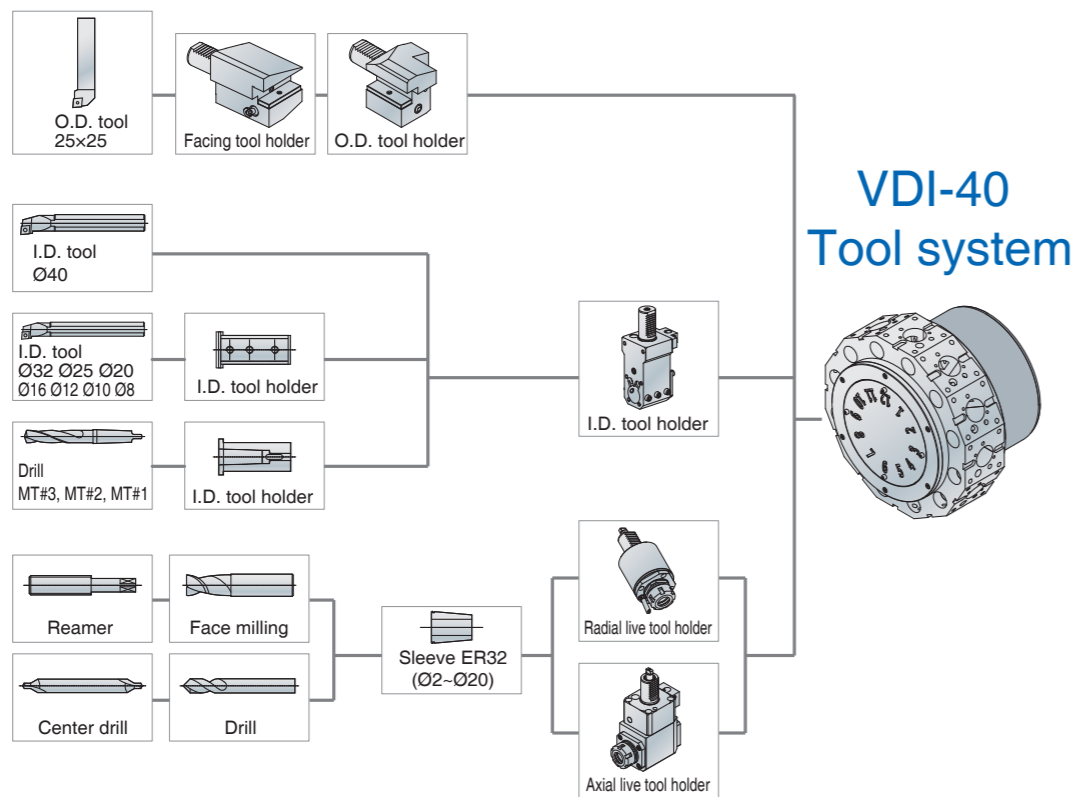

Unit : mm

Unit : mm

Tool interference

12V VDI40 tool

Unit : mm

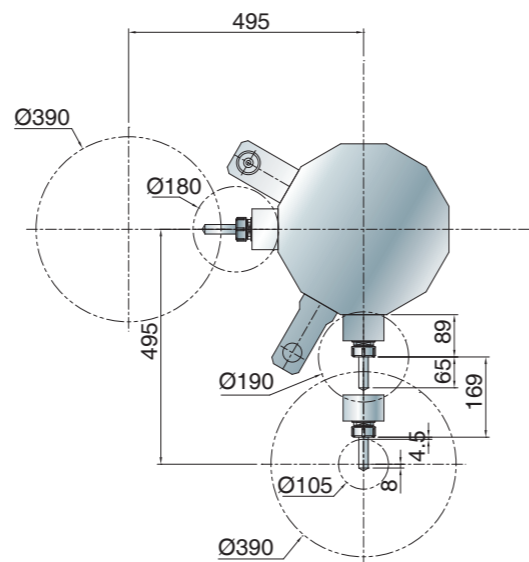
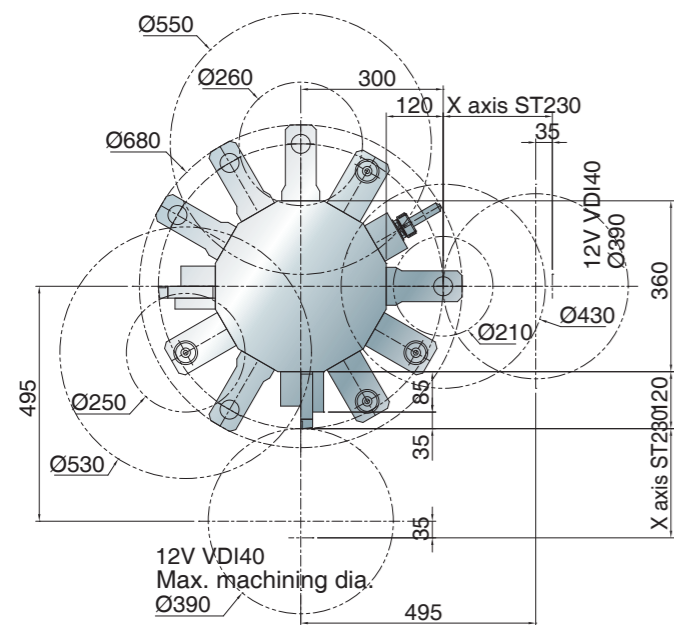

12V BMT65 tool

Unit : mm

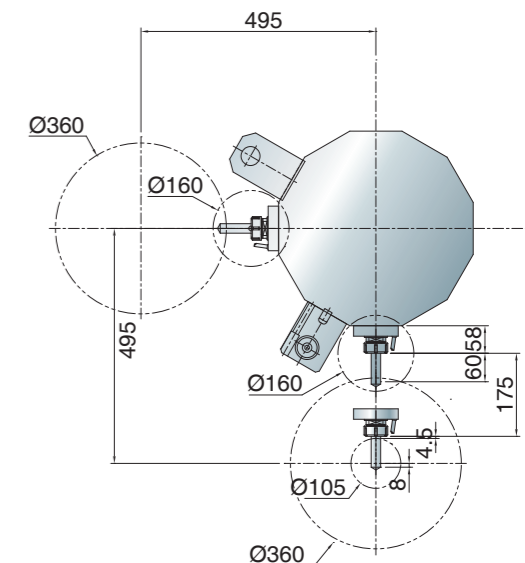
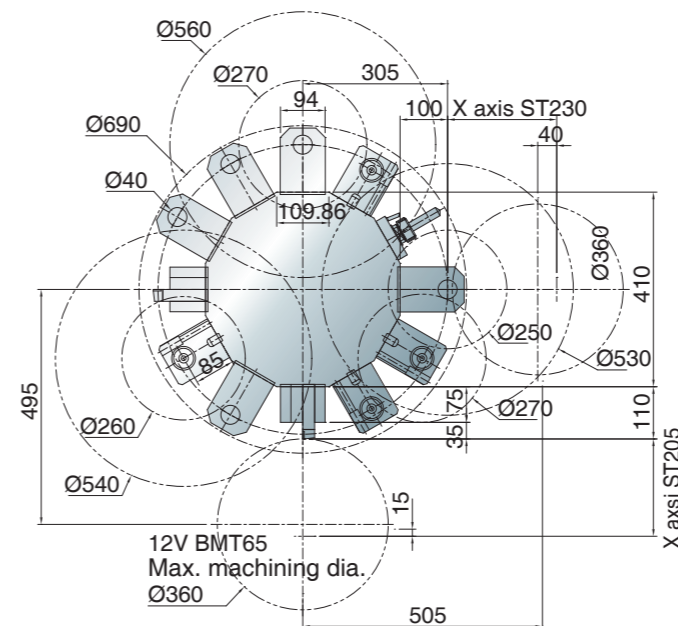

16V VDI-30 tool

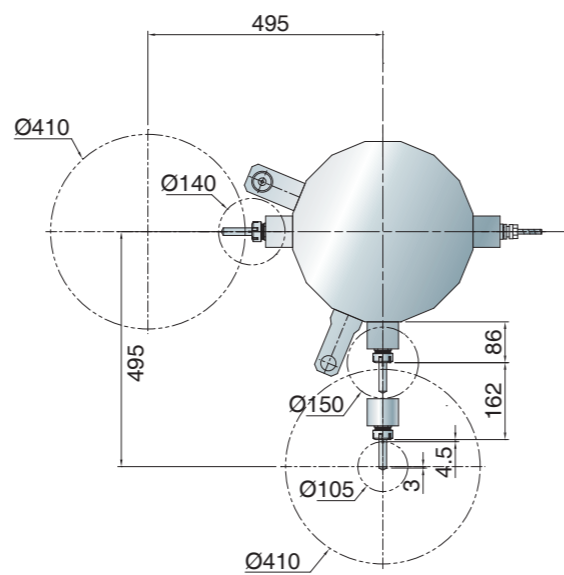
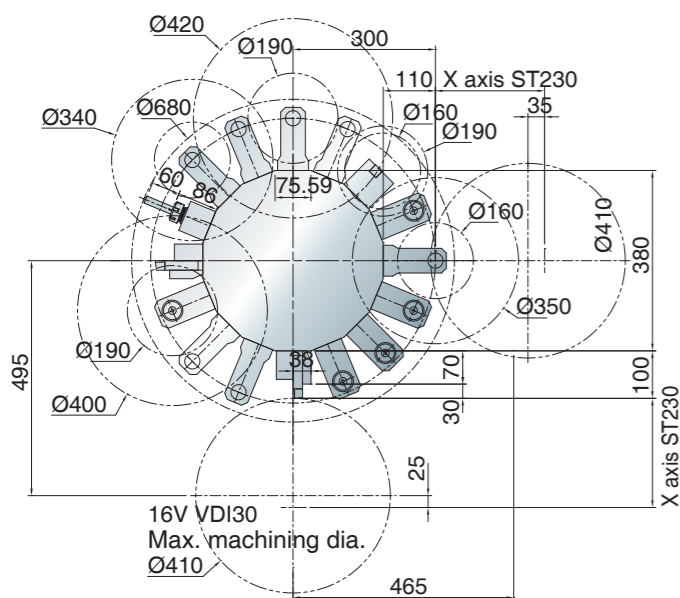

16V BMT-55 tool

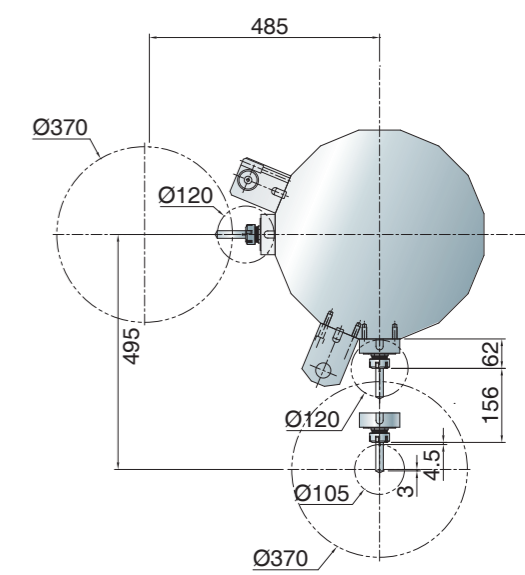
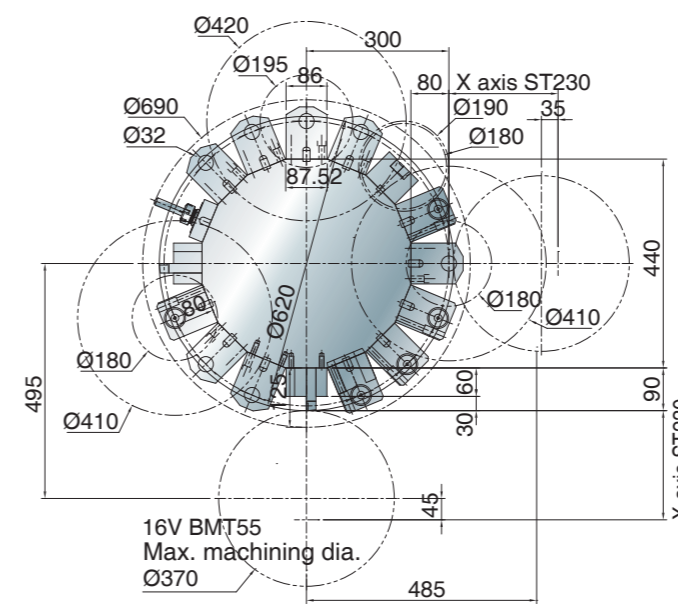

Working area

TD-2000Y 12V/VDI-40 tool

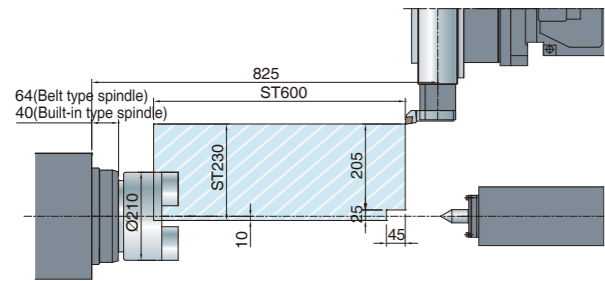
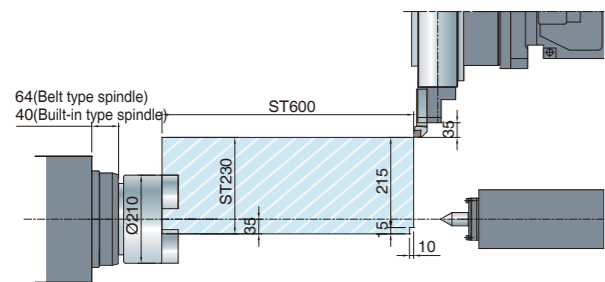
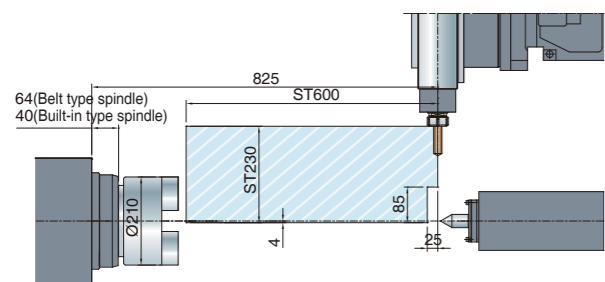
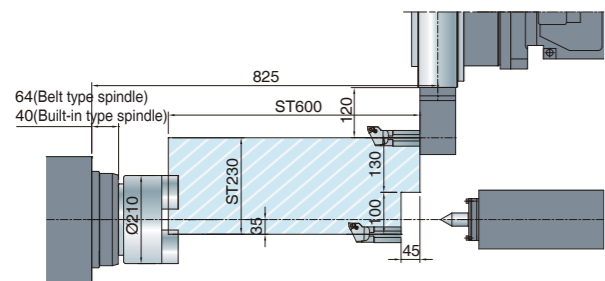
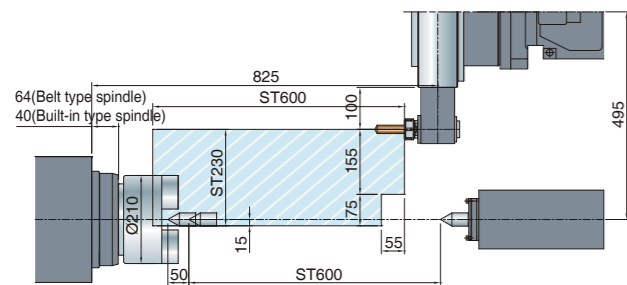

TD-2000Y 16V/VDI-30 tool

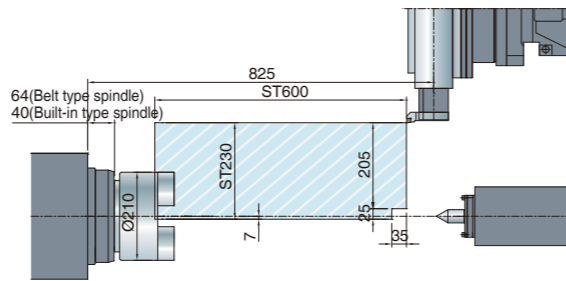
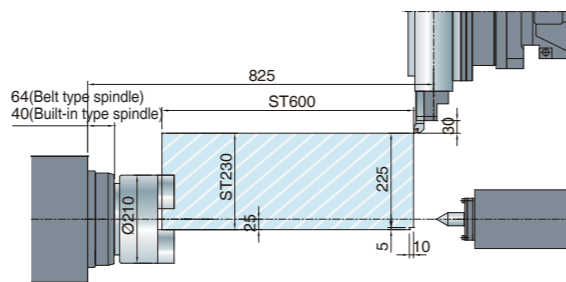
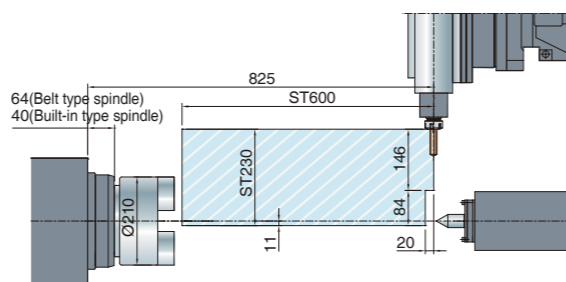
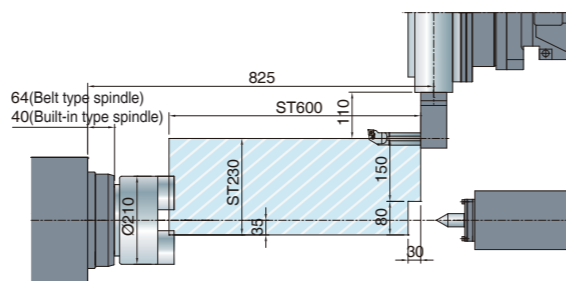
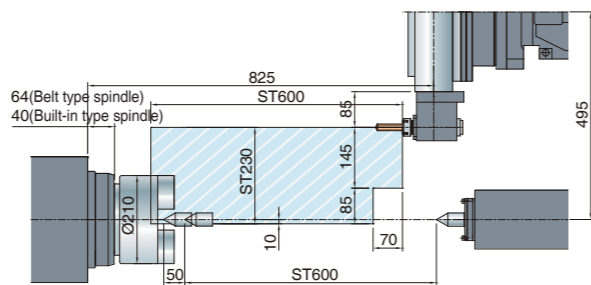

TD-2000Y 12V/BMT-65 tool

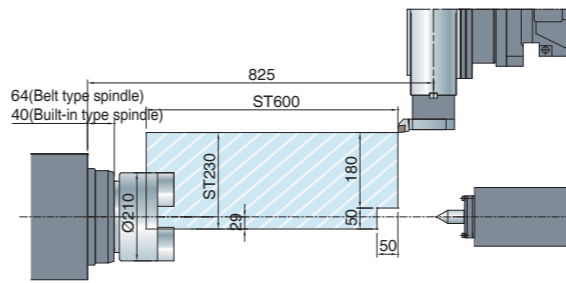
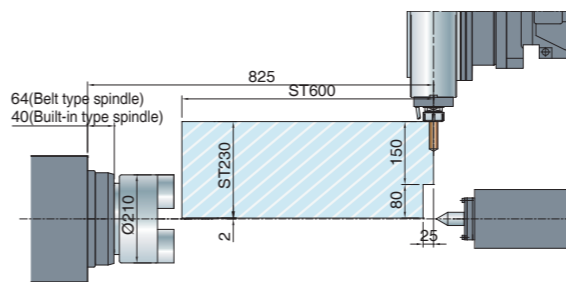
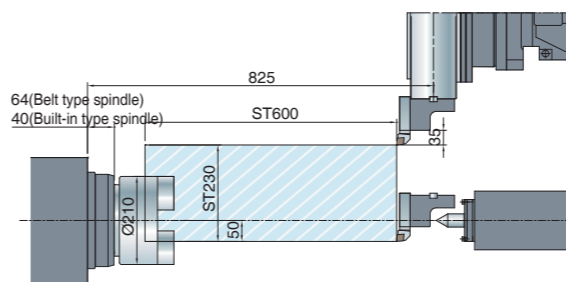
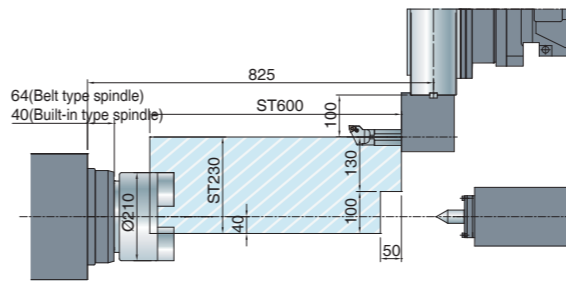
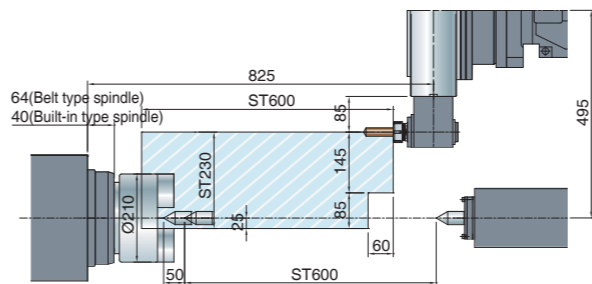

TD-2000Y 16V/BMT-55 tool

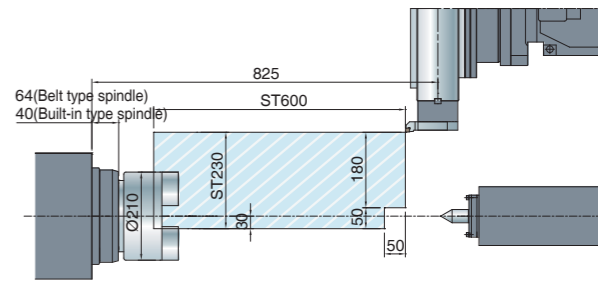
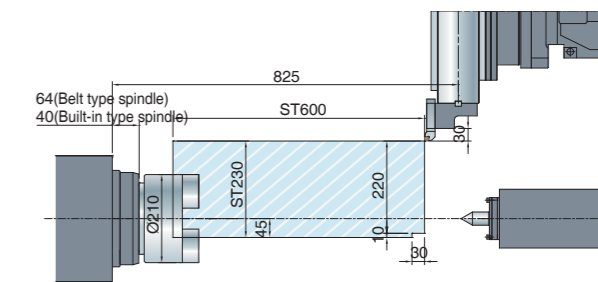
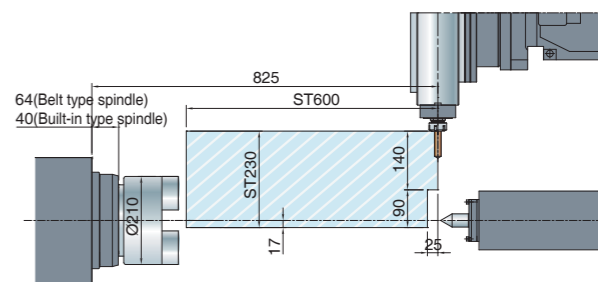
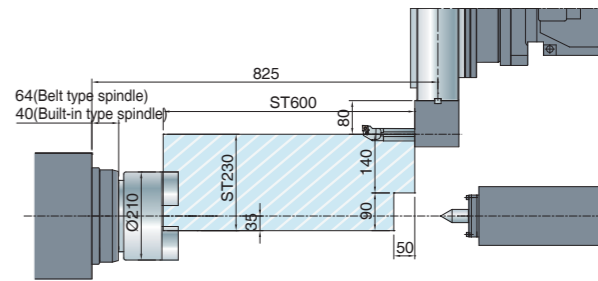
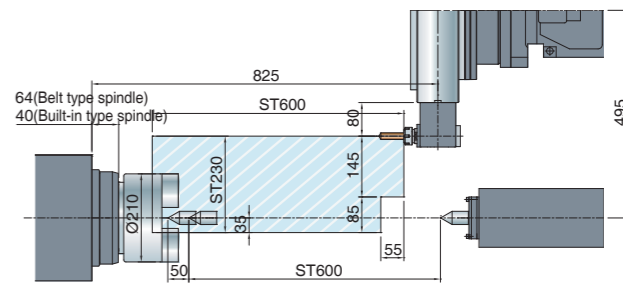

Unit : mm

Unit : mm

Working area

TD-2000YB(C) 12V/VDI-40 tool

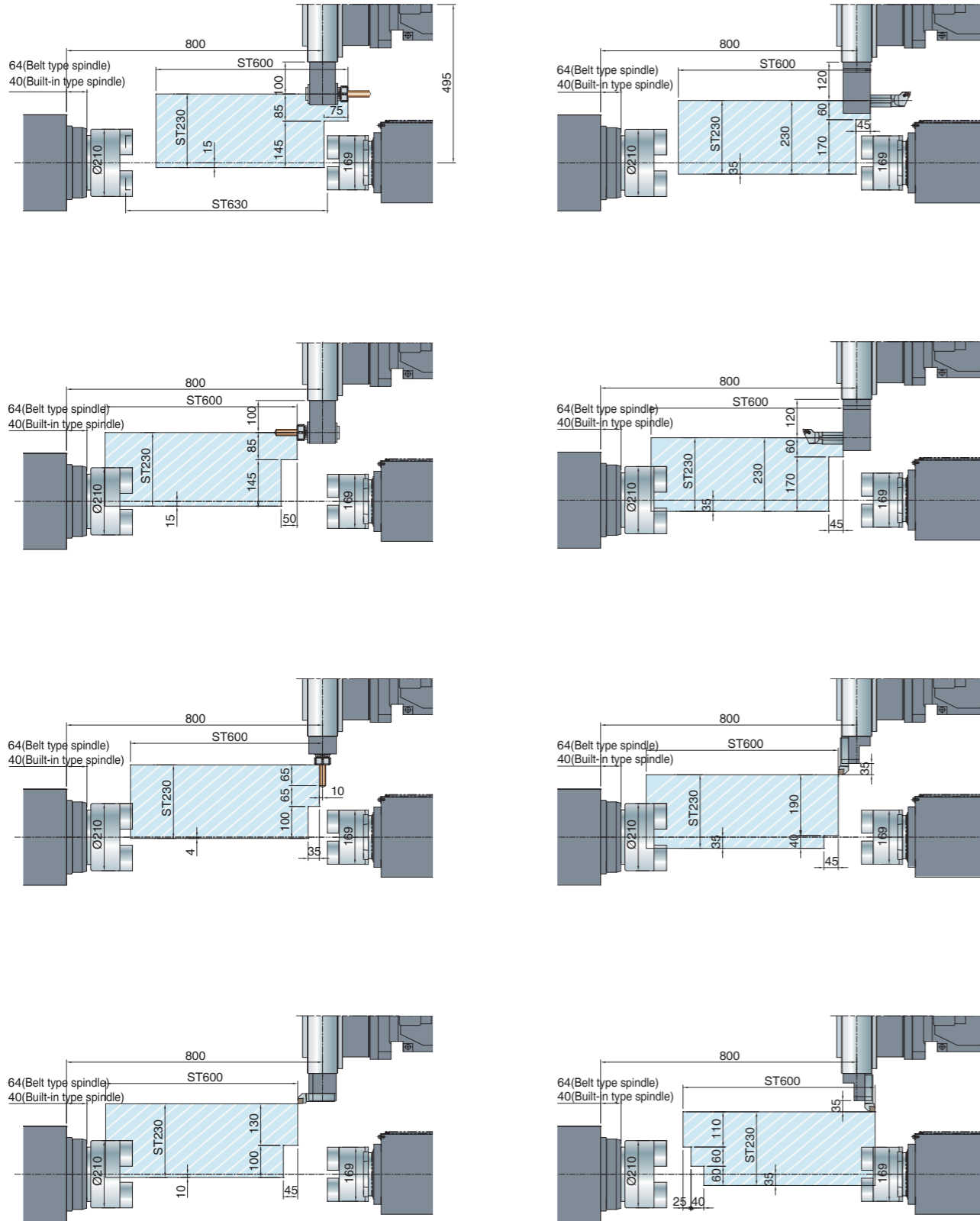

Unit : mm

TD-2000YB(C) 16V/VDI-30 tool

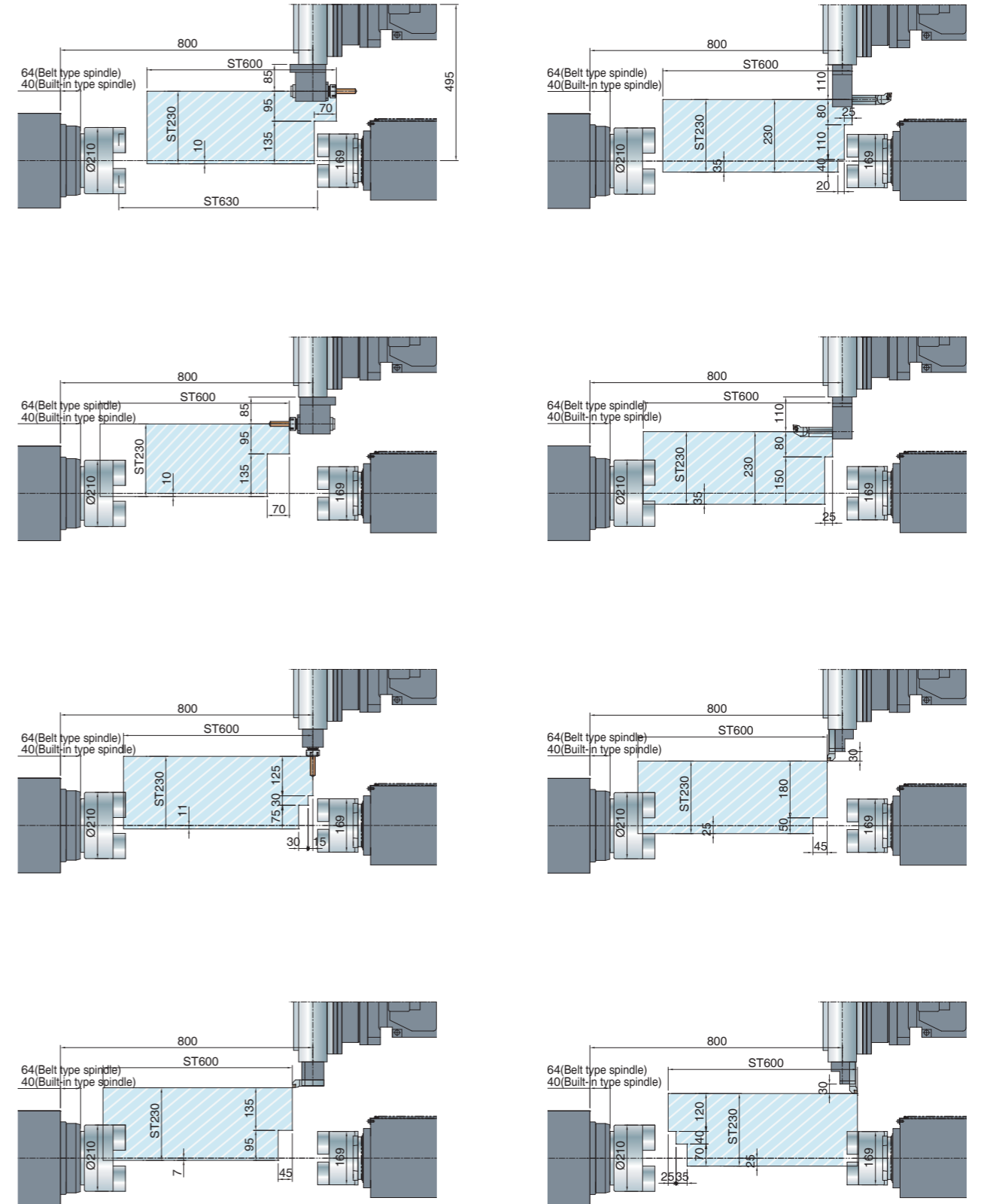

Unit : mm

Working area

TD-2000YB(C) 12V/BMT-65 tool

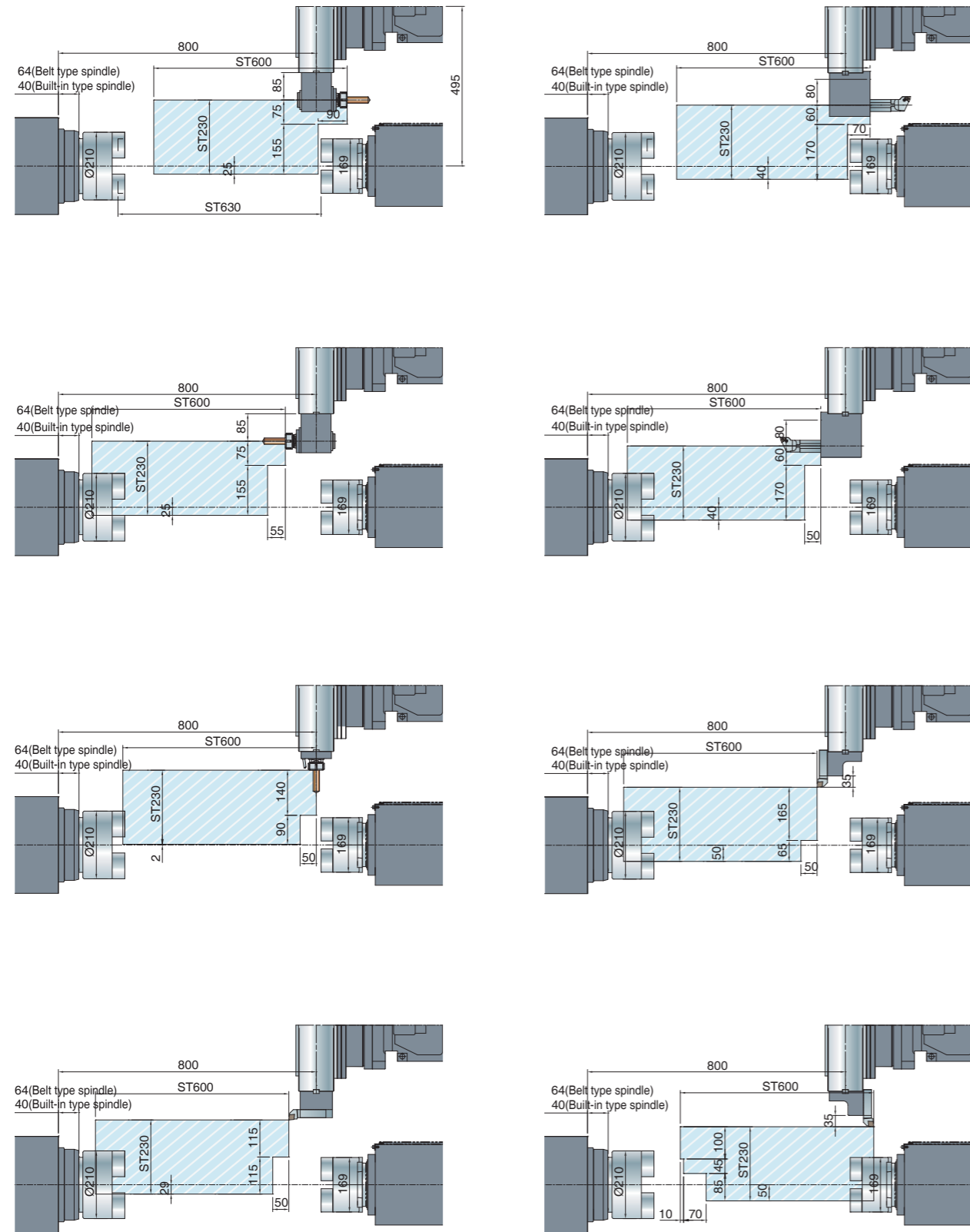

Unit : mm

TD-2000YB(C) 16V/BMT-55 tool

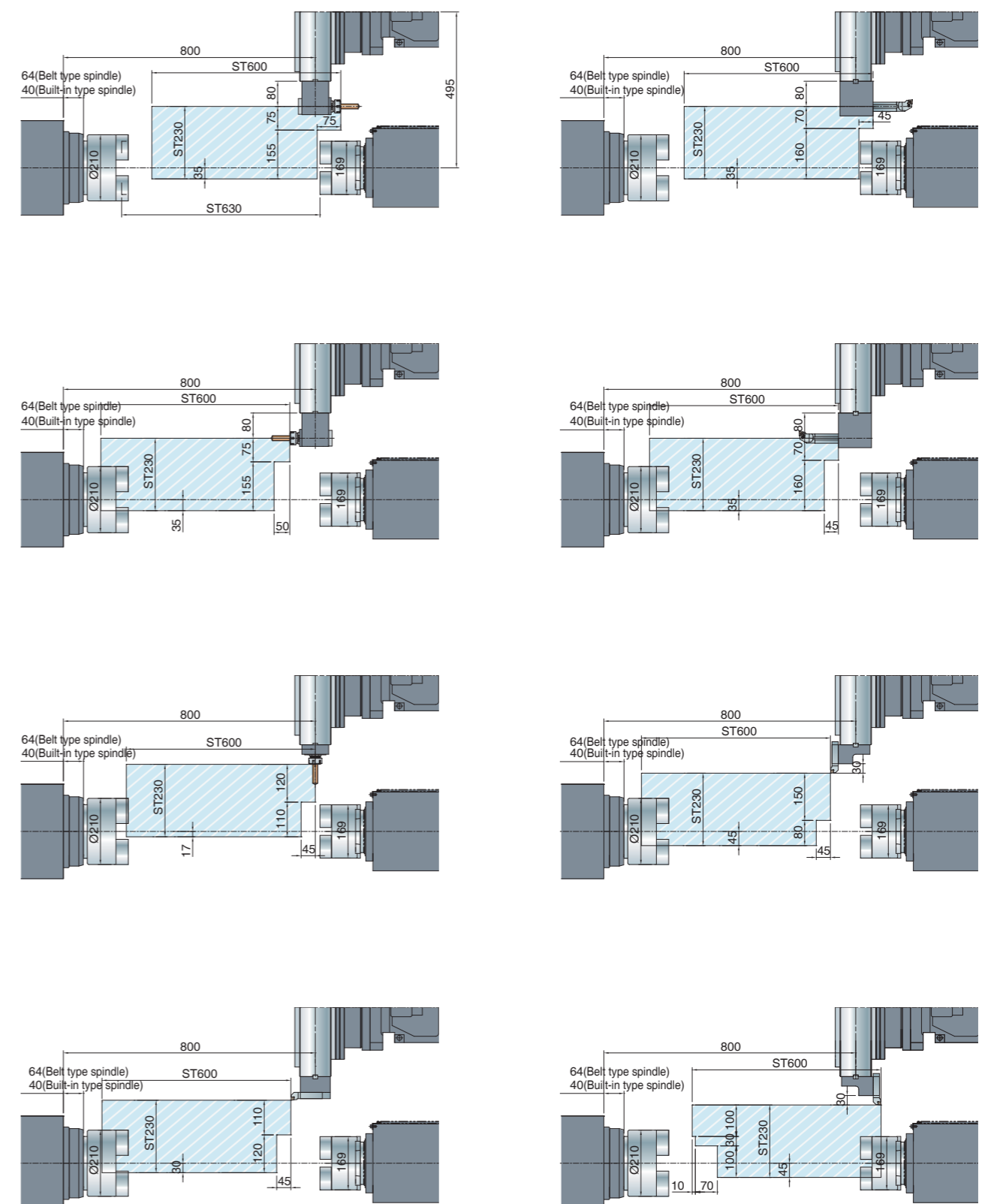

Unit : mm

Standard/optional accessories

Standard : ● Optional : ○ Non-support : -

		TD-2000			TD-2500		
		Y	YB	YBC	Y	YB	YBC
Spindle	Belt-driven spindle, spindle bearing dia. Ø100 mm, 4500 rpm (3,000 rpm)	●	●	●	-	-	-
	Built-in spindle, spindle bearing dia. Ø100 mm, 6,000 rpm	○	○	○	-	-	-
	Belt-driven spindle, spindle bearing dia. Ø120/Ø130 mm, 3,500 rpm (2,500 rpm)	-	-	-	●	●	●
	Built-in spindle, spindle bearing dia. Ø120 mm, 5,000 rpm	-	-	-	○	○	○
	Built-in spindle, spindle bearing dia. Ø130 mm, 3,500 rpm	-	-	-	○	○	○
Sub spindle	Built-in spindle, spindle bearing dia. Ø90 mm, 5000 rpm	-	●	●	-	●	●
	0.001°	-	-	●	-	-	●
Tailstock taper	MT#4	●	-	-	●	-	-
	Hydraulic driving	●	-	-	●	-	-
	Servo driving	○	-	-	○	-	-
Power turret	12V BMT-65	●	●	●	●	●	●
	12V VDI-40	○	○	○	○	○	○
	16V BMT-55	○	○	○	○	○	○
	16V VDI-30	○	○	○	○	○	○
Chuck	3 Jaws through hole chuck				●		
	Collet type through hole chuck				○		
Tool holder	I.D. tool holder				○		
	Face turning tool holder				○		
	O.D. tool holder				○		
	Axial live tool holder				○		
	Radial live tool holder				○		
	Axial face milling tool holder				○		
	I.D. tool holder for sub-spindle				○		
	Face turning tool holder for sub-spindle				○		
	O.D. tool holder for sub-spindle				○		
	Axial live tool holder for sub-spindle				○		
	Radial live tool holder for sub-spindle				○		
	Cutting tool holder for sub-spindle				○		
	I.D. tool sleeve Ø8, Ø10, Ø12, Ø16, Ø20, Ø25				○		
	Drilling tool sleeve MT#1, MT#2, MT#3				○		
Chip conveyor	Hinge type conveyor				●		
	Scraper type conveyor				○		
	Magnetic scraper type conveyor				○		
Lubrication system	General lubrication system				●		
	LHL integrated lubrication system				○		
Hydraulic unit	General type oil pump				●		
	variable-frequency oil pump				○		
Automatic loading/unloading unit	Bar feeder				○		
	Parts catcher				○		
	Parts conveyor				○		
	Automatic door				○		
	Parts unloading device for sub-spindle				○		
Coolant & airblow	Coolant through spindle				○		
	Air blow through spindle				○		
	Coolant on spindle side				○		
	Air blow on spindle side				○		
Others	Air conditioner for electrical cabinet				○		
	Air gun / Coolant gun				○		
	Oil skimmer				○		
	Oil mist collector				○		
	FANUC 0i-T				●		

Specifications · Machine dimension

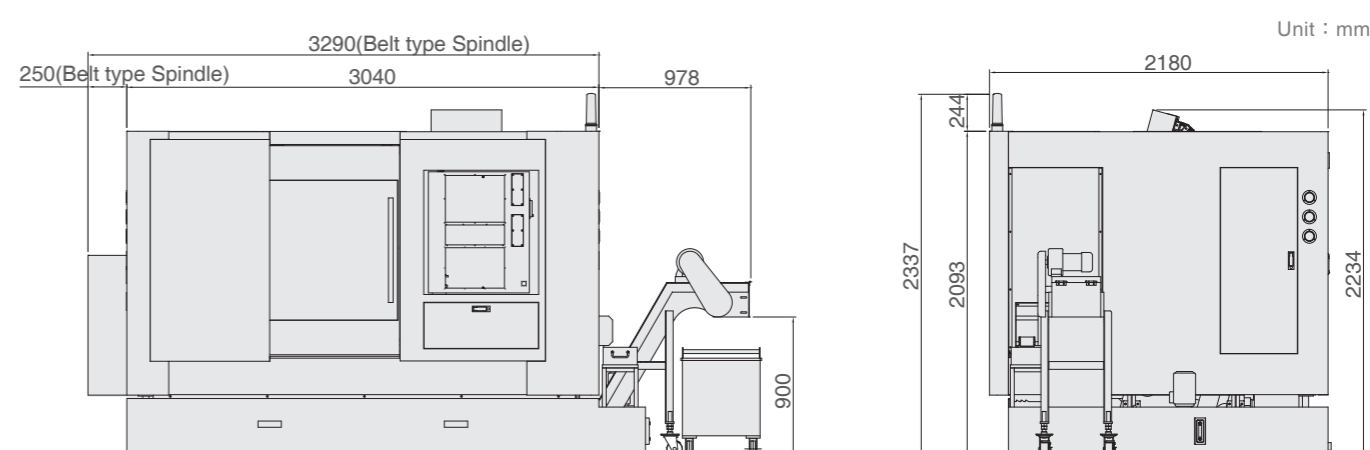

Item	Specification	Unit	TD-2000Y[BC]				TD-2500Y[BC]				
			VDI-40	VDI-30	BMT-65	BMT-55	VDI-40	VDI-30	BMT-65	BMT-55	
Turning capacity	Max. swing diameter	mm	Ø700				Ø700				
	Max. swing diameter over saddle	mm	Ø310				Ø310				
	Max. turning diameter	mm	Ø390	Ø410	Ø360	Ø370	Ø390	Ø410	Ø360	Ø370	
	Max. turning length	mm	560	570	530	535	560	570	530	535	
Spindle	Spindle nose		A2-6				A2-8				
	Spindle speed	rpm	4,500 (3,000)				3,500 (2,500)				
	Chuck size	inch	8"(10")				10" (12")				
	Through-spindle hole diameter	mm	Ø62				Ø77 (Ø86)				
	Bar capacity	mm	Ø51				Ø64 (Ø74)				
	Spindle bearing diameter	mm	Ø100				Ø120/Ø130				
	Spindle center to floor	mm	1,075				1,075				
	Min. CS axis indexing increment	deg	0.001°				0.001°				
	Sub-spindle	Spindle nose		- [A2-5]				- [A2-5]			
		Spindle speed	rpm	- [5,000]				- [5,000]			
Chuck size		inch	- [6"] (8")				- [6"] (8")				
Through-spindle hole diameter		mm	- [Ø35]				- [Ø35]				
Spindle bearing diameter		mm	- [Ø90]				- [Ø90]				
Min. CS axis indexing increment		deg	- [0.001°]				- [0.001°]				
Power turret	Tool shank		VDI-40	VDI-30	BMT-65	BMT-55	VDI-40	VDI-30	BMT-65	BMT-55	
	Tool capacity	pc	12	16	12	16	12	16	12	16	
	O.D. tool	mm	25x25	20x20	25x25	20x20	25x25	20x20	25x25	20x20	
	I.D. tool	mm	Ø40	Ø32	Ø40	Ø32	Ø40	Ø32	Ø40	Ø32	
	Max. speed	rpm	6,000				6,000				
	Spindle motor	kW	5.5/3.7				5.5/3.7				
	Max. tool diameter		Dia. 20/M16	Dia. 16/M14	Dia. 20/M16	Dia. 16/M14	Dia. 20/M16	Dia. 16/M14	Dia. 20/M16	Dia. 16/M14	
Feed	X/Y/Z/B axis travel	mm	230/±51/600/- [630]				230/±51/600/- [630]				
	X/Y/Z/B axis rapid traverse	m/min	30/15/30/- [30]				30/15/30/- [30]				
	X/Z axis cutting feedrate	mm/rev	0.001-500				0.001-500				
Hydraulic tailstock	Tailstock travel	mm	600 [-]				600 [-]				
	Center taper		MT4 [-]				MT4 [-]				
	Center diameter	mm	100 [-]				100 [-]				
Servo type tailstock (Opt.)	Tailstock travel	mm	600 [-]				600 [-]				
	Center travel	mm	80 [-]				80 [-]				
	Center taper		MT4 [-]				MT4 [-]				
	Center diameter	mm	100 [-]				100 [-]				
Hydraulic unit	Hydraulic tank capacity	L	30				30				
	Hydraulic motor	kW	1.5				1.5				
Coolant unit	Coolant tank capacity	L	400				400				
	Coolant pump motor	kW	0.55				0.55				
Motor	Spindle motor	kW	18.5/15/11				18.5/15/11				
	Sub-spindle motor	kW	- [7.5/5.5]				- [7.5/5.5]				
	X/Y/Z/B axis servo motor	kW	4.5/2.7/4.5/- [2.7]				4.5/2.7/4.5/- [2.7]				
Machine size	Width×depth×height	mm	3,290x2,180x2,337				3,290x2,180x2,337				
	Weight	kg	5,900 [6,400]				6,100 [6,600]				
Controller			Fanuc 0i-TF				Fanuc 0i-TF				

©Specifications May Be Changed Without Prior Notice.

©Specifications May Be Changed Without Prior Notice.