

Driven & Static Tool Holder



Radial ER Tapping Tool Holder (External Coolant)

DIN 1809

- Tool Holder is produced in accordance with DIN 69880.
- Driven Coupling is according to DIN 1809.
- ER Collet is according to DIN 6499.
- For left hand and right hand turret.

Gear Ratio : 1 : 1

R.P.M. : Max. 3,000 RPM

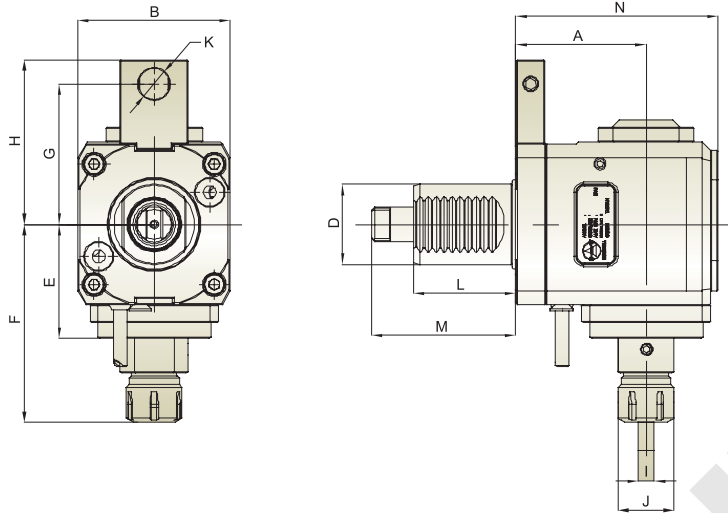

Unit : mm

Model No.	A	B	D	E	F	G	H	I	J	K	L	M	N	N.W.(KG)
THB-B15.65-40A	65	76	40	57	99	56/6370	68/75/82	M3~M12	28	16	51	72	101	4.9

Angle Adjustable Tool Holder (External Coolant)

- Cutting angle can be set from +90 to -90 degree for various applications.

Gear Ratio : 1 : 1

R.P.M. : Max. 4,000 RPM

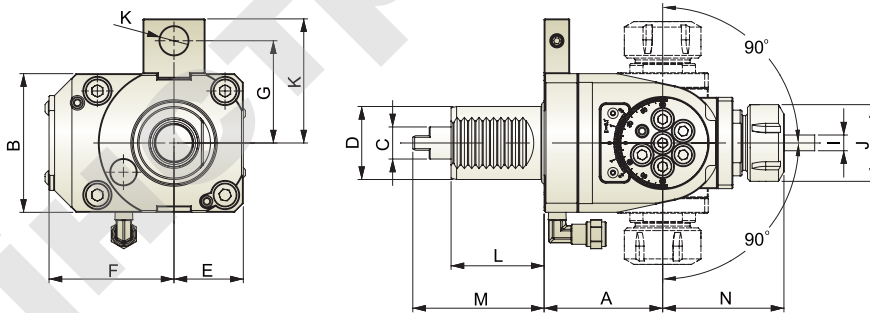

Unit : mm

Model No.	A	B	C	D	E	F	G	H	I	J	K	L	M	N	N.W.(KG)
THB-E04.65-40A	65	76	18	40	38	68.5	63/70	75/82	ER25 (2~16)	42	16	51	68	66.5	4.65

※ Optional Accessories : Hooker Spanner.