



Driven & Static Tool Holder



Axial Offset Tool Holder (External Coolant)

DIN 1809

- Tool Holder is produced in accordance with DIN 69880.
- Driven Coupling is according to DIN 1809.
- ER Collet is according to DIN 6499.
- For left hand and right hand turret.

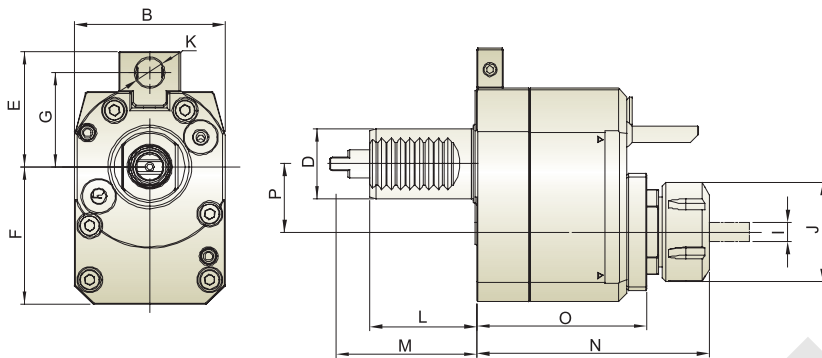

	Gear Ratio : 1 : 1
	R.P.M. : Max. 5,000 RPM



Unit : mm

Model No.	B	D	E	F	G	I	J	K	L	M	N	O	P	N.W.(KG)
THB-C04.29-30A	64	30	57	58.5	48	ER25 (2~16)	42	12	45	62	99.5	73	29	3.0
THB-C05.50-40A	80	40	75/82	85	63/70	ER32 (3~20)	50	16	51	72	110	77.5	50	6.0

Axial Offset Tool Holder (Internal Coolant)

	Gear Ratio : 1 : 1
	R.P.M. : Max. 5,000 RPM
	Internal Coolant : 70 bar

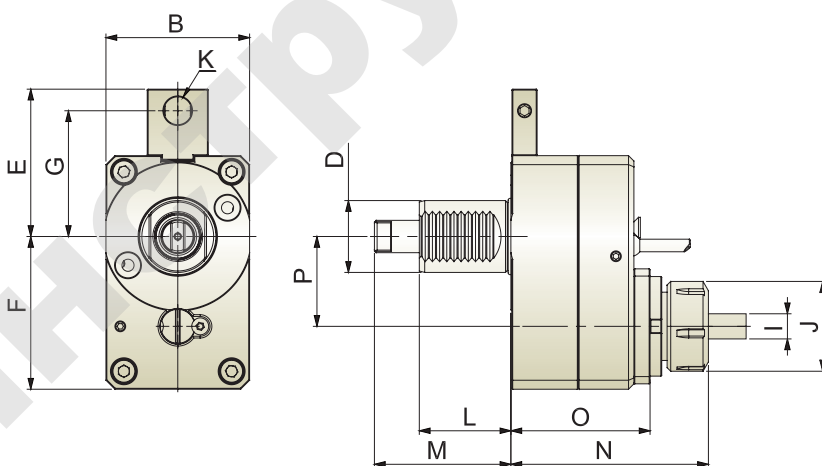

Unit : mm

Model No.	B	D	E	F	G	I	J	K	L	M	N	O	P	N.W.(KG)
THB-C04.29-30AI	64	30	57	58.5	48	ER25 (2~16)	42	12	45	62	109.5	83	29	3.3